

**AA120M Atlas Sound Mixer Amplifier**

*Specifications are subject to change without notice*



**AtlasSound.com**

1601 JACK MCKAY BOULEVARD ENNIS, TEXAS 75119 U.S.A. • TELEPHONE: (800) 876-3333 • FAX: (800) 765-3435



TABLE OF CONTENTS

Safety Instructions...2
Introduction, Features, and Applications...3
Safety Precautions...4
Front Panel Description...6
Rear Panel Description...7
Quick Start Examples...15
Wiring the AA120M...21
Rack Mount Kit...22
Internal Jumper Locations...23
Block Diagram...24
Specifications...27
Warranty...28

SAFETY INSTRUCTIONS

Please be sure to read all the instructions carefully before using this product.

- Many safety messages are included in this manual, please be sure to observe these as they are important.
We recommend that you keep this manual close by for future reference.
Do not install this device in dusty or humid locations, or in direct exposure to sunlight.
Prevent the power cord from damage, pinching or being walked on, in particular, the plug and where the cord attaches to the amplifier.
Do not defeat the polarized or grounding feature of the power cord plug.
Use only the accessories and attachments specified in this manual.
Disconnect the power cord during electrical storms, or when the product will be unused for long periods.
Have servicing done only by qualified personnel.

Specifications are subject to change without notice



AtlasSound.com



The lightning flash with arrowhead within a triangle is intended to tell the user that parts inside the product are a risk of electric shock to persons.



The exclamation point within a triangle is intended to tell the user that important operating and servicing instructions are in the papers with the appliance.

### INTRODUCTION

Congratulations and thank you for purchasing the Atlas Sound Model AA120M professional grade mixer/ amplifier. An integral part of the AA Series of commercial products, the AA120M was engineered and integrated with unique features to assist the contractor/installer in today's commercial business audio environment.

### FEATURES

- Zone 1 output 120W
- Zone 2 output 1W@ 8Ω
- Zone 3 output 1.5V@ 600Ω
- Inputs 1-4 mic/line switchable
- Input 5 line level
- 1 Module Input
- Inputs 1-4 and 6 can send or receive mute commands
- 2 Mute Buses, 1 VOX, and 1 contact closure
- 1 Tape and 1 Line outputs
- Mute assignable internal relay
- 24VDC available on rear panel for priority attenuators
- Pre-amp out-Power amp in loop
- Bridge In/Output - Allows mix bus combining of multiple AA120Ms

### APPLICATIONS

- Industrial paging
- Retail paging and BGM
- Commercial PA
- Priority volume control applications
- Hotel ballroom/meeting rooms

Specifications are subject to change without notice



AtlasSound.com



**SAFETY PRECAUTIONS**

- Read the instructions very carefully before using this product.
- Observe the instructions in this manual as conventions of safety; symbols and messages regarded as important precautions are included.
- Retain this manual for future reference.

**Message Conventions and Safety Symbols**

Before installing and operating this product, read this manual so you are fully aware of the potential safety hazards and understand the safety symbols and messages. The safety symbols and messages shown below are used in this manual to prevent bodily injury and property damage from mishandling.



**WARNING** Indicates a potentially hazardous situation which, if mishandled, could result in death or serious injury.



**CAUTION** Indicates a potentially hazardous situation which, if mishandled, could result in moderate or minor personal injury, and/or property damage.



**WARNING WHEN INSTALLING THE PRODUCT**

- Do not expose the product to rain or in an environment where it may be exposed to water or other liquids, which may result in fire or electric shock.
- Operate the product only with the voltage specified on the unit. Fire and/or electric shock may result if a higher voltage is used.
- Do not modify, kink, or cut the power cord. Do not place the power cord on close proximity to heaters and do not place heavy objects on the power cord, including the product itself, doing so may result in fire or electric shock.
- Replace the protective cover over the speaker terminals after installation. Do not touch the 70V speaker terminals as electric shock may result.
- Ensure that the safety ground terminal is connected to a proper ground. Never connect the ground to a gas pipe as a catastrophic disaster may result.
- Be sure the installation of the product is stable, avoid slanted surfaces as the product may fall and cause injury or property damage.



**WARNING WHEN THE DEVICE IS IN USE**

- To prevent electric shock, do not remove the product cover as there are high voltage components inside. Refer all servicing to Atlas Sound.
- Should any of the following irregularities occur during use, immediately switch off the power, disconnect the power cord from the AC outlet and contact Atlas Sound. Do not attempt to continue operation with the product as this may cause fire or electric shock.
  - Smoke or strange smell coming from the unit.
  - If the product falls or the case is damaged.

*Specifications are subject to change without notice*



**AtlasSound.com**



- If water or any metallic objects falls, into the product.
- If the power supply cord is damaged in any way.
- If the unit is malfunctioning.
- Do not insert or drop metallic objects or flammable materials into the ventilation holes of the product's cover, as this may result in electric shock or fire.
- Do not place any containers with liquid or metallic objects on the top of the product. If any liquid spills into the unit, fire or electric shock may result.
- Never operate this product or touch the power supply cord during an electrical storm, electric shock may result.
- Never exceed the wattage on the product when connecting equipment. Fire and or property damage may result.



**CAUTION WHEN INSTALLING THE PRODUCT**

- Plugging in or unplugging the power cord with wet hands may result in electric shock.
- Never move the unit with the power cord plugged into the wall, as damage to the power cord may result. When unplugging the cord from the wall, grasp the plug, **NOT** the cord.
- Never block the panel vents in the product's cover. Heat buildup may result inside the unit and fire may result.
- Never install this product in humid or dusty locations, nor in direct sunlight, near sources of heat, or in areas where sooty smoke or steam in present. Fire and electric shock may result.



**CAUTION WHEN THE PRODUCT IS IN USE**

- When powering the product up for the first time, ensure that the volume controls are turned down. Unexpected high sound pressure levels may be present at the speakers and result in hearing loss.
- Never place heavy objects on the product, causing it to fall and or break, resulting in personal injury and property damage. In addition, the product itself may fall and cause injury and property damage.
- Never operate the product for extended periods with the sound in a distorted condition. This is an indication of a malfunction, which may result in excessive heat being generated and causing a fire.
- Contact Atlas Sound for instructions on cleaning the inside of the unit. Large accumulations of dust inside the unit may result in heat buildup and fire.
- Ensure that the power supply plug in securely plugged into the wall outlet. Never allow dust to accumulate on the power plug or inside the wall outlet.
- When cleaning the unit or the unit is not to be operated for an extended time period, unplug the power cord from the wall.

*Specifications are subject to change without notice*



**AtlasSound.com**



FRONT PANEL DESCRIPTION

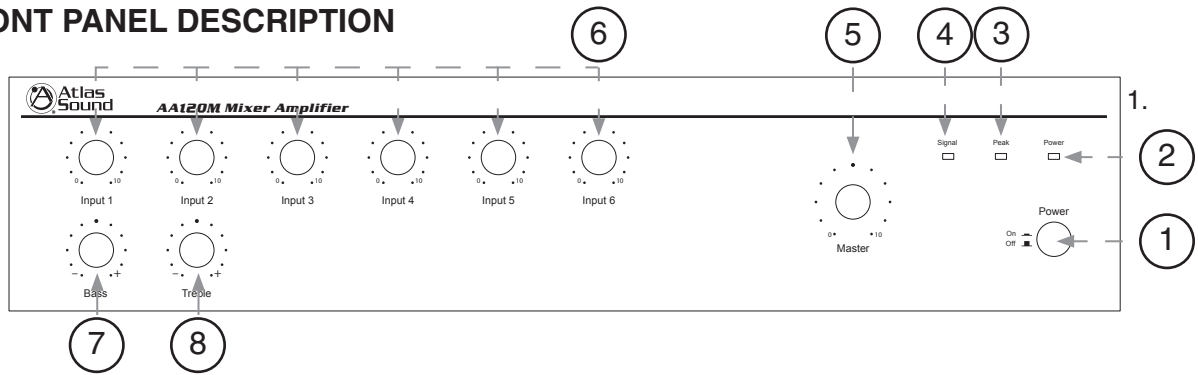

1. Power Switch

This push on/push off switch applies power to the AA120M.

2. Power LED

This LED illuminates when the power switch is turned on.

3. Peak LED

The PEAK LED will illuminate when the AA120M is in a clipping condition, caused by excessively high input levels or a GAIN control is turned up too high. An occasional flash is OK.

4. Signal LED

This LED will assist you in setting gain structure into the amp. With a source connected to the amp and playing, turn up the channel gain control until this LED just starts to flash. Once all the sources connected are playing, the SIGNAL LED may be on solid. This condition is normal.

5. Master Gain Control

The MASTER GAIN CONTROL will raise or lower all the input channels together. A good starting point for setting gain structure is to set MASTER GAIN CONTROL at the 12:00 position, and then adjust the individual channels one at a time.

6. Input 1-6 Controls

The gain for input channels 1-6 are controlled by these rotary controls. The MASTER GAIN CONTROL must be turned up in addition to the input controls for audio to be present at the speaker terminals.

7. Bass Control

Normally set at the 12:00 position, rotating clockwise will increase (boost) bass frequencies by 10dB at 100Hz. Rotating counter-clockwise from the 12:00 position will decrease (cut) bass frequencies by 10dB at 100Hz

8. Treble Control

Normally set at the 12:00 position, rotating clockwise will increase (boost) treble frequencies by 10dB at 10kHz. Rotating counter-clockwise from the 12:00 position will decrease (cut) treble frequencies by 10dB at 10kHz.

Specifications are subject to change without notice



AtlasSound.com



REAR PANEL DESCRIPTION

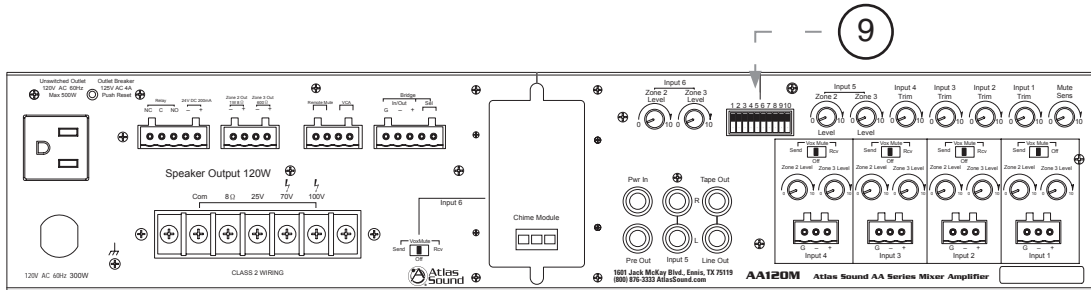

9. Dipswitch 1-10

Understanding the functionality of the dipswitches is key to getting the most out of the AA120M. Whether a switch is in the "Up" or "Down" position is critical to the function of the amplifier. Note: Mispositioning any of these switches may cause harm to the speakers or amplifier. We recommended powering off the amplifier prior to making any switch selections. Pay close attention to the assignment chart and manual for proper settings.

1	2	3	4	5	6	7	8	9	10
Low Cut	VCA	Phantom	Relay Act	Input 6	Input 5	Input 4	Input 3	Input 2	Input 1
On	Input 5	On	Vox	Amp Dir	300mV	Mic	Mic	Mic	Mic
Off	Master	Off	CC	Mix Bus	100mV	Line	Line	Line	Tel/Line

**Dipswitch 1- LOW CUT** – When in the "ON" position, frequencies below 400Hz are attenuated at the rate of 6dB per octave. Note: The rotary bass control is bypassed when the LOW CUT filter is engaged. We suggest that when paging horns are connected to the AA120M, engage the LOW CUT filter to prevent the horns from operating below their cutoff frequency. When "OFF", the amplifier operates full bandwidth.

**Dipswitch 2- VCA** – When set to the "Master" position, the VCA control port acts as a system remote volume control, adjusting all the input channels up or down simultaneously. When set to the "Input 5" position, the VCA remote control port affects only the level of INPUT 5.

**Dipswitch 3- PHANTOM** – When set to the "OFF" position, PHANTOM POWER is turned off on INPUTS 1-4. When set to the "ON" position, PHANTOM POWER (24VDC) is available on INPUTS 1-4.

**Dipswitch 4- Relay ACT** - When set to the "CC" position, the internal relay is triggered by contact closure (see page 32). When set to the "VOX" position, the internal relay is triggered by audio signals at INPUTS 1-4 and INPUT 6, depending upon their rear panel switch setting.

Specifications are subject to change without notice



AtlasSound.com

1601 JACK MCKAY BOULEVARD ENNIS, TEXAS 75119 U.S.A. • TELEPHONE: (800) 876-3333 • FAX: (800) 765-3435

©2006 ATLAS SOUND LP

Printed in U.S.A.

00106

ATS002179 RevA 01/06

PP



1	2	3	4	5	6	7	8	9	10
Low Cut	VCA	Phantom	Relay Act	Input 6	Input 5	Input 4	Input 3	Input 2	Input 1
On	Input 5	On	Vox	Amp Dir	300mV	Mic	Mic	Mic	Mic
Off	Master	Off	CC	Mix Bus	100mV	Line	Line	Line	Tel/Line

**Dipswitch 5 - Input 6** - When set to the "Mix Bus" position, INPUT 6 signals are routed to the Mix Bus and are **POST** Input Gain, **POST** Zone 2 and 3 Outputs and **PRE** Tone Controls. When set to the "Amp Direct" position, INPUT 6 signals go directly to the final amplifier stage, and are **PRE** Input Gain, **PRE** Zone 2 and 3 Outputs and **POST** Tone Controls.

**Dipswitch 6 - Input 5** - When set to the "100mV" position, the sensitivity of Input 5 is suitable for inputting Telephone Paging Signals. When set to the "300mV" position, the sensitivity of Input 5 is suitable for CD/DVD player outputs.

**Dipswitch 7 - Input 4** - When set to the "Line" position, Input 4 sensitivity is suitable for CD/DVD line level outputs. When set to the "Mic" position, Input 4 sensitivity is suitable for microphone input.

**Dipswitch 8 - Input 3** - When set to the "Line" position, Input 3 sensitivity is suitable for CD/DVD line level outputs. When set to the "Mic" position, Input 3 sensitivity is suitable for microphone input.

**Dipswitch 9 - Input 2** - When set to the "Line" position, Input 2 sensitivity is suitable for CD/DVD line level outputs. When set to the "Mic" position, Input 2 sensitivity is suitable for microphone input.

**Dipswitch 10 - Input 1** - When set to the "Tel/Line" position, Input 1 sensitivity is suitable for CD/DVD line level outputs. When set to the "Mic" position, Input 1 sensitivity is suitable for microphone input.

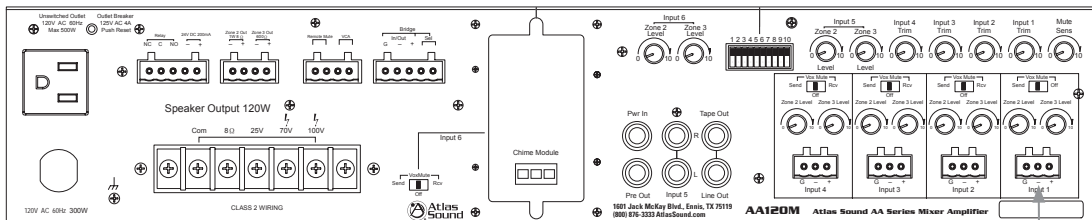

10

10. Input 1

Balanced mic or line level signals connect to the (+), (—), and (G) terminals. Refer to the chart at the top of the page for the following setting. Dipswitch number 10, labeled Input 1 must be set to the proper position for mic or line level. If you are connecting an unbalanced line level input, tie (short) the (G) and (—) terminals together. An optional Input Isolation Transformer is available if a ground loop problem exists. See page 23 for installation. Contact Atlas Sound for more details on the Input Isolation Transformer.

Specifications are subject to change without notice



AtlasSound.com

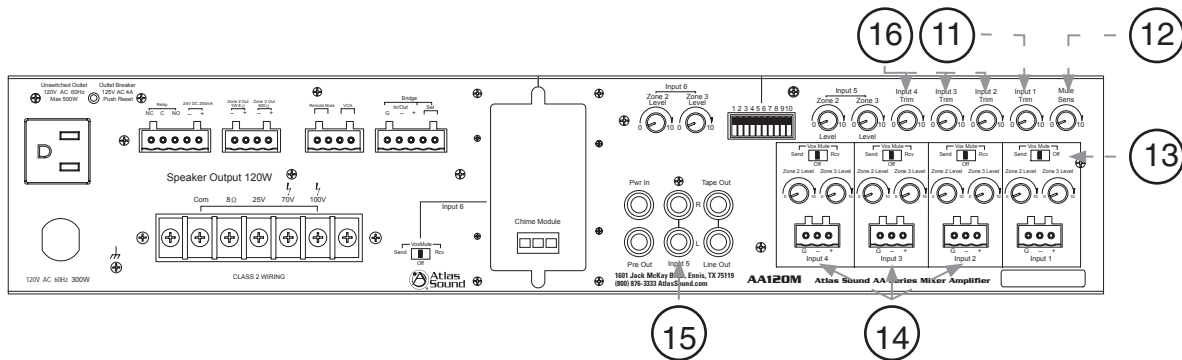

11. Input 1 Trim

This variable control adjusts the sensitivity of INPUT 1. When the dipswitch is set to "Mic" it allows fine tuning of the input gain structure to the AA120M. There is 20dB of variable gain available. This feature is **PRE** channel level control.

12. Mute Sens For Vox Mute Bus

This control adjusts how sensitive the mute send circuitry on INPUT 1, 2, 3, 4, or 6 reacts. Setting the control fully counter-clockwise will lower the sensitivity, and a higher amplitude signal will be required at INPUT 1, 2, 3, 4, or 6 to trigger the mute send circuits. Fully clockwise will raise the sensitivity of the mute circuits, where a lower amplitude signal will trigger a mute send. **Careful calibration of this control may be required to fully utilize the mute circuits' capabilities.**

13. Mute Send On/Off

Set to the "On" position, and audio is present at INPUT 1, a mute command will be sent to the VOX Mute bus, thereby muting any channels set to "MUTE RCV". When set to the "Off" position, no Mute commands will be sent.

14. Inputs 2, 3, and 4

Balanced mic or line level signals connect to the (+) (-) and (G) terminals. Refer to the chart above "Multi Function Dipswitch" for the proper setting for mic or line level operation. If you are connecting an unbalanced line level input, tie (short) the (G) and (-) terminals together.

15. Input 5

INPUT 5 consists of stereo summing RCA jacks. These are suitable for connection to the output of CD/DVD players. Note: INPUT 5 has factory installed mute features, please refer to Section 17 VOX Mute Swith and Section 18 Remote Mute for details.

16. Input Trim Controls, Channels 2, 3, and 4

This variable control adjusts the MIC sensitivity of INPUT 2, 3, and 4 allows fine-tuning of the input gain structure to the AA120M. There is 20dB of variable gain available. This feature is **PRE** channel level control.

Specifications are subject to change without notice



AtlasSound.com

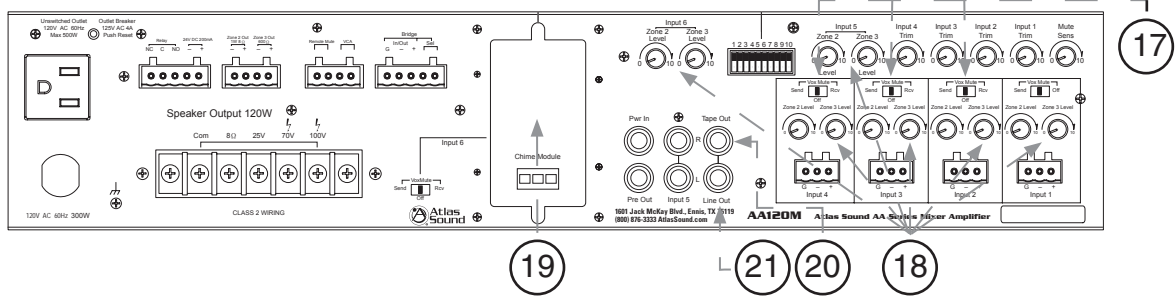

17. VOX Mute Switch For Channels 2, 3, 4, and 6

Each 3-position switch sets the VOX mute status individually for Inputs 2, 3, 4, and 6. **Note: All VOX Mute settings are over ridden when the internal Remote Mute jumpers are installed and the contacts are connected together.** Input 5 is shipped with an internal VOX Mute jumper installed and will be muted when any channel is set to Mute Send and signal is present at the corresponding input.

**SEND** - Sends a (VOX) Mute command when audio is present at the input to other channels set to (VOX) Mute RCV (Receive).

**OFF** - Bypasses the (VOX) Mute Send and RCV (Receive) functions.

**RCV (VOX Receive)** - Inputs will be Muted when other Input Channels are set to to the (VOX) Mute Send position and audio is present at the corresponding input.

18. Zone 2 And Zone 3 Level Controls

These rotary controls will vary the signal level at the Zone 2 and Zone 3 output terminals. Fully counter-clockwise (0) is off, fully clockwise (10) is the maximum output level. Both Zone 2 and 3 level controls are **PRE** channel level controls for Inputs 1, 2, 3, 4, 5, and 6. **Note: Zone 2 and 3 level controls function identically to their corresponding inputs.** See number 28 for more details.

19. Input 6 Module Slot

The Module Slot accepts optional industry standard input modules from Atlas and other vendors. Contact Atlas Sound for a full list of module types.

20. Tape Out

Line level mono signals are available at this jack for connection to recording devices. The signal available here is **PRE** tone control and low cut filter and comes from the internal mix bus.

21. Line Out

The LINE OUT connector is useful for providing unbalanced line level signal to another amplifier or other external devices. Prior to using this feature one must understand where the internal signal pick up point is so you can decide if it is correct for your application. We suggest you refer to the block diagram of the AA120M to have a complete understanding of the signal flow.

**Note the following conditions for LINE OUT**

- A. **Pre** Low Cut Filter
- B. **Post** Tone Controls (meaning the settings for the Bass and Treble controls affect this signals output).  
Note: Refer to "Low Cut Filter Switch for complete understanding of the LCF feature."
- C. **Post** Amp In (meaning any signal that is inserted into the Pre AMP In jack will be present at the Line Out).

Specifications are subject to change without notice



AtlasSound.com

1601 JACK MCKAY BOULEVARD ENNIS, TEXAS 75119 U.S.A. • TELEPHONE: (800) 876-3333 • FAX: (800) 765-3435

©2006 ATLAS SOUND LP

Printed in U.S.A.

00106

ATS002179 RevA 01/06

PP

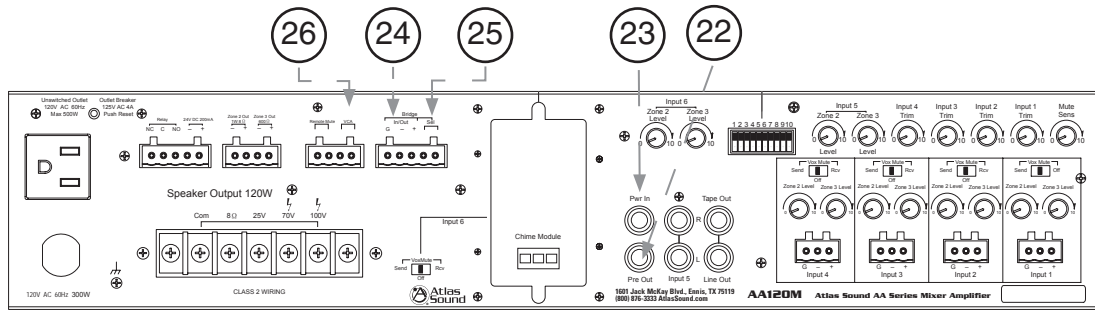

22. Pre Out

The PRE OUT connector has **Post** tone control signals available to drive another power amp or external audio devices. Use in conjunction with the AMP IN connector, an effects loop can be created by connecting the PRE OUT jack to a device such as an equalizer then back out to the AMP IN connector. See the connection diagram in the setup section of this manual.

23. Pwr In

The AMP IN connector is useful for converting the AA120M into a slave amp. When a line level signal is connected to this input, the internal connection between the preamp and internal power amp is broken. Audio signals applied to this connector are post tone control and pre master control.

24. Bridge In/Out

Certain installations have the need to combine one or more mixers together. These mixers may be in different rooms of an install but have the need to share a page or music throughout the installation. These terminals provide a way to send and receive balanced line level signals from the internal mix bus of the AA120M. The "BRIDGE IN/OUT" feature is **PRE** Tone Controls and Low Cut Filter. The Bridge In/Out feature allows you to send and receive a balanced signal. This is important for allowing longer distances between the mixers. Note: This function should only be done with other Atlas Sound mixers that have this feature. The Send and Receive signals are combined through the same terminals. To activate this feature see Bridge Sel below.

25. Bridge Sel

The "**Bridge Select (Sel)**" terminals are the access point to activate the "**Bridge In/Out**" feature. To activate the feature connect the two points together via an external contact closure. These two points must be connected to send or receive any signal. By connecting the **Bridge In/Out** terminals of two AA120M, a simple room combining system can be accomplished. If using a remote switch and closing it, the "**Bridge Select (Sel)**" will combine the amps as one, opening the switch will separate the two amps. Note: If combining 3 or 4 mixers together the output level will have to be adjusted before and after Bridge Sel terminals are connected (shorted) together. We suggest utilizing the Remote Level control when using this feature.

26. VCA

Remote location of the level control can be accomplished via the VCA control port. You can control the overall level (Master) or just Input 5. This selection is made via Dipswitch position #2. Connect the two leads from the optional remote volume control to these terminals. This remote level control is **POST** Master and Input 5 Level Controls. Set the system's maximum levels using the amplifier level controls and then use the remote VCA potentiometer as an attenuator from the maximum levels set. See the VCA setup section for instructions on wiring up the potentiometer.

Specifications are subject to change without notice



AtlasSound.com

1601 JACK MCKAY BOULEVARD ENNIS, TEXAS 75119 U.S.A. • TELEPHONE: (800) 876-3333 • FAX: (800) 765-3435

©2006 ATLAS SOUND LP

Printed in U.S.A.

00106

ATS002179 RevA 01/06

PP

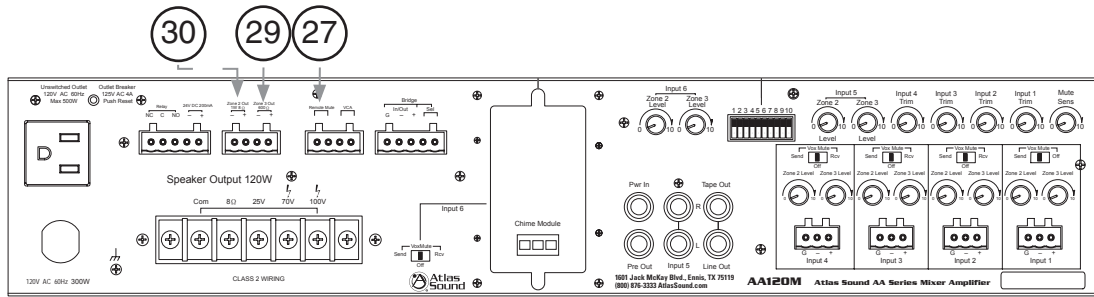

27. Remote Mute (Priority Mute)

The Remote Mute feature allows you to have priority mute over Inputs 2-6. It is useful when certain channels need to be muted from a remote location. When shorting (connecting) the Remote Mute terminals together, (G) and (M), the internally assigned channels will be muted and will override the VOX Mute settings. Note: Input 1 cannot be VOX or Remote Muted at anytime. Input 5 is the only channel shipped with a factory installed Remote Mute jumper. See the PCB diagram on page 23 for Remote Mute jumper assignments.

28. Zone 2 And Zone 3 Mute Assign (Special Internal Feature)

Each input has a mute assignment function. Inputs 2-6 can be set to receive or send a mute command. Each input also has individual Zone 2 and 3 level controls. There may be applications that require different mute options with Zone 2 and 3 outputs. You may want a certain input muted but not necessarily the corresponding Zone outputs.

Internally, there are jumpers to select each input's zone outputs to be PRE or POST input mute assignment. The AA120M Zone 2 and 3 outputs are shipped with the following assignments:  
Inputs 2, 3, and 4 are **POST** input mute assignment.  
Inputs 5 and 6 are set to be **PRE** input mute assignment.

*Example:* Input 5 will commonly have a CD player inserted into it for background and/or MOH. The CD's signal is fed to the amplifier output for background music and the same signal from the CD is routed to a telephone systems MOH input via Zone 2 or 3 output. When Input 1 receives a page you may want the CD to be muted for the background music but not the telephone's MOH. For this to work, the internal Zone 2 or 3 jumpers for Input 5 need to be assigned to **PRE** Mute. See the PCB diagram on page 23 for pin assignments.

29. Zone 3 Out

MUSIC ON HOLD port, also known as MOH. The Zone 3 signal is taken **PRE** Input gain.

30. Zone 2 Out

The 8Ω 1W Zone 2 output can drive an external 8Ω speaker, and is taken **PRE** Input gain.

Specifications are subject to change without notice



AtlasSound.com

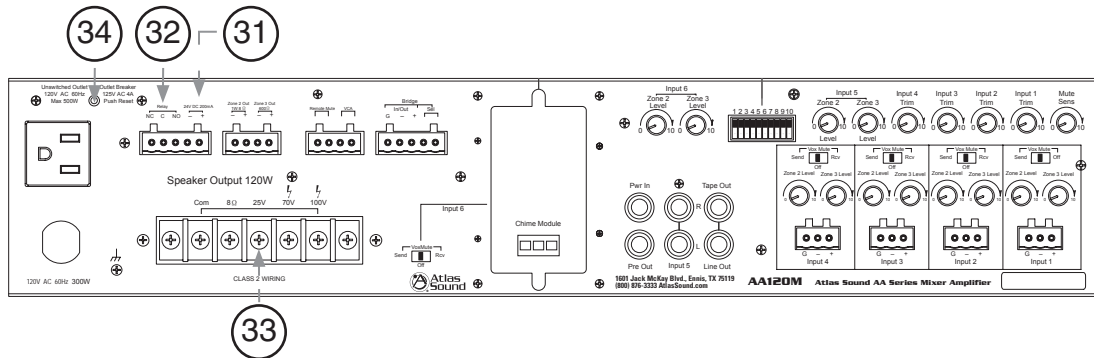

31. 24VDC Terminals

24VDC is available on these terminals and can supply current up to 250mA. This DC output is useful for supplying DC voltage to trigger Atlas PA series attenuators.

**Note: Do not short these terminals together or ground them.**

32. Relay

The AA120M supplies contact points to trigger an external component. The SPDT (single pole double throw) set of relay contacts have (C) Common, (NO) Normally Open, and a (NC) Normally Closed contacts available on these terminals - 500mA Max. The relay can be activated via two methods, remote contact closure or VOX mute. Refer to Dipswitch #4 "Relay Act" for relay trigger selection.

The (CC) Contact Closure setting works in conjunction with the Remote Mute feature. Refer to section 27 "REMOTE MUTE" for detailed information.

The (VOX) setting works in conjunction with a Mute Send from an assigned Input channel. Refer to section 17 the "MUTE SWITCH" for detailed information. This feature is also known as VOX.

33. Loudspeaker Terminals

For loudspeaker connections, connect as follows or proceed to the setup section for typical wiring diagrams.

**COM** - Speaker common or negative connection

**8 OHM** - Connect to direct coupled loudspeakers

**25V** - Connect to transformer coupled, 25V loudspeakers with a total load impedance of no less than 5.2Ω

**70V** - Connect to transformer coupled, 70.7V loudspeakers with a total load impedance of no less than 41.6Ω

**100V** - Connect to transformer coupled, 100V loudspeakers with a total load impedance of no less than 83Ω

34. Circuit Breaker

The circuit breaker is designed to trip and shut down the AA120M "Unswitched Outlet". After correcting the cause of the breaker tripping, reset the breaker by pushing in on the tab.

Specifications are subject to change without notice



AtlasSound.com

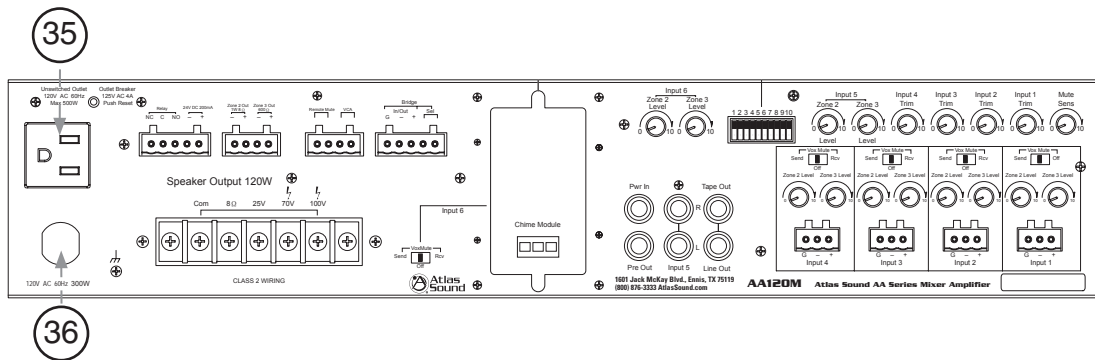

**35. Unswitched Outlet**

The 120VAC outlet is energized at all times when the AA120M power cord is connected to a live duplex outlet. The unswitched outlet provides power for other devices (Atlas rack work light, etc.). Keep the total power draw below 500W.

**36. Power Cord**

Connect the power cord to 120VAC only. Serious damage may result if accidentally connected to other line voltages.

*Specifications are subject to change without notice*



**AtlasSound.com**

1601 JACK MCKAY BOULEVARD ENNIS, TEXAS 75119 U.S.A. • TELEPHONE: (800) 876-3333 • FAX: (800) 765-3435

©2006 ATLAS SOUND LP

Printed in U.S.A.

00106

ATS002179 RevA 01/06

PP



QUICK START EXAMPLES

Example 1 - System Paging, BGM, and MOH with Emergency Page Override

When a page signal is received from INPUT 2 and the RMT MUTE terminals are shorted, the page will be the only audio heard in the main system because BGM will be muted. If an emergency page comes into INPUT 1, all inputs will be muted except for the emergency page. Note: Zone 3 MOH output will not be muted or affected by either page scenario.

- Connect a paging mic to INPUT 1. This will be the priority emergency page over ride mic input. Note: The INPUT 1 Trim and Sens will need to be adjusted after all the settings and connections have been set.
- Connect a paging mic with a switch to INPUT 2.
- Connect the switch wires from the mic connected to INPUT 2 to the "RMT MUTE" terminals. Note: The polarity on the switch to the terminals does not matter.
- Set Dipswitch 9 and 10 to the "MIC" position.
- Set INPUT 1 to **Mute Send**.
- Set INPUT 2 to **Mute RCV**.
- Connect a BGM player to INPUT 5. Note: The input gain of this channel may need to be changed for proper level balance. Dipswitch 6 allows you to select between a 100mV or 300mV input sensitivity.
- Connect Zone 3 output to the MOH input on your telephone system. Adjust Input 5's Zone 3 output level as needed.

Dipswitch Settings

- Dipswitch 1 - OFF
- Dipswitch 2 - OFF (Not affected)
- Dipswitch 3 - Depends on mic type
- Dipswitch 4 - OFF (Not affected)
- Dipswitch 5 - OFF (Not affected)
- Dipswitch 6 - Set to the required gain
- Dipswitch 7 - OFF
- Dipswitch 8 - OFF
- Dipswitch 9 - ON (Mic)
- Dipswitch 10 - ON (Mic)

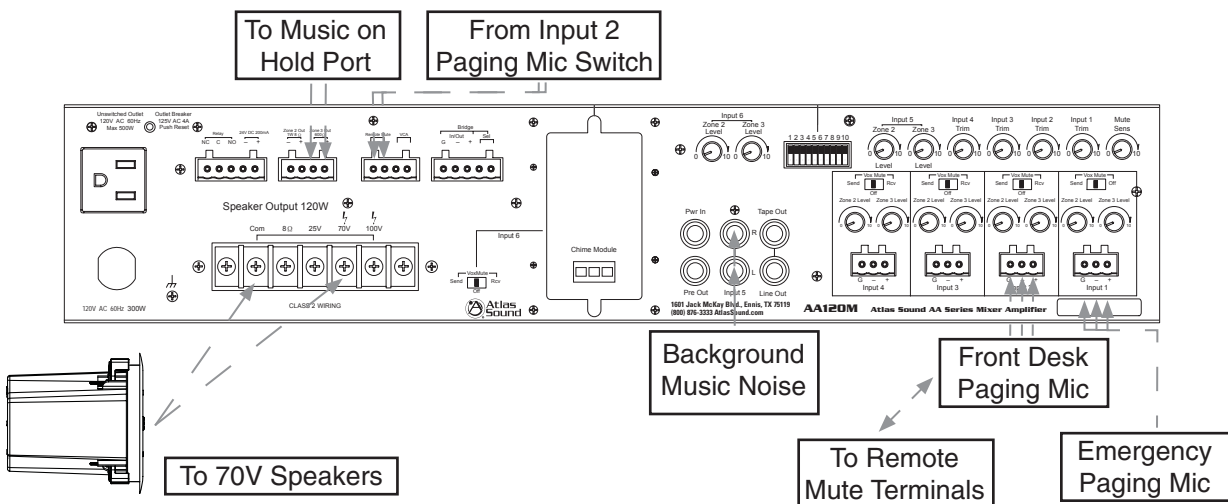

Example 1

Specifications are subject to change without notice



AtlasSound.com



**Example 2 - Priority Attenuator Override Application with Message Repeater and BGM**

This application makes use of the internal relay and 24VDC in conjunction with Atlas Sound optional "PA" override volume controls. A typical scenario would be for a Fire Station, where the background music is turned down by the wall volume controls in the evening. A page is received on INPUT 1 and the VOX mute triggers the AA120M relay sending 24VDC to the attenuator engaging the internal override relay and allowing the page to come through alerting the sleeping firemen. A message repeater is connected for caller on hold playback. Note: Remote BGM level control can also be accomplished via the VCA control for INPUT 5.

- Connect a mic to INPUT 1. Note: The INPUT 1 **Trim** and **Sens** will need to be adjusted after all the settings and connections have been set.
- Set Dipswitch 10 to the "**MIC**" position.
- Set INPUT 1 to **Mute Send**.
- Connect the telephone message repeater to INPUT 2.
- Set INPUT 2 to **Mute OFF**. Turn down INPUT 2 volume control so no audio will be present at the speaker terminal.
- Connect Zone 3 to the Telephone PBX MOH port. Adjust INPUT 2 **Zone 3 Level** as needed.
- Connect a BGM player to INPUT 5. Note: The input gain of this channel may need to be change for proper level balance. Dipswitch 6 allows you to select between a 100mV or 300mV input sensitivity.
- Connect the external level controls to the 70V speaker output.

**Dipswitch Settings**

- |                                   |  |
|-----------------------------------|--|
| Dipswitch 1 - OFF                 | Dipswitch 2 - OFF (Not affected)               |
| Dipswitch 3 - Depends on mic type | Dipswitch 4 - ON (VOX)                         |
| Dipswitch 5 - OFF (Not affected)  | Dipswitch 6 - Set to the required gain         |
| Dipswitch 7 - OFF                 | Dipswitch 8 - OFF                              |
| Dipswitch 9 - OFF (Line)          | Dipswitch 10 - ON (Depends upon source signal) |

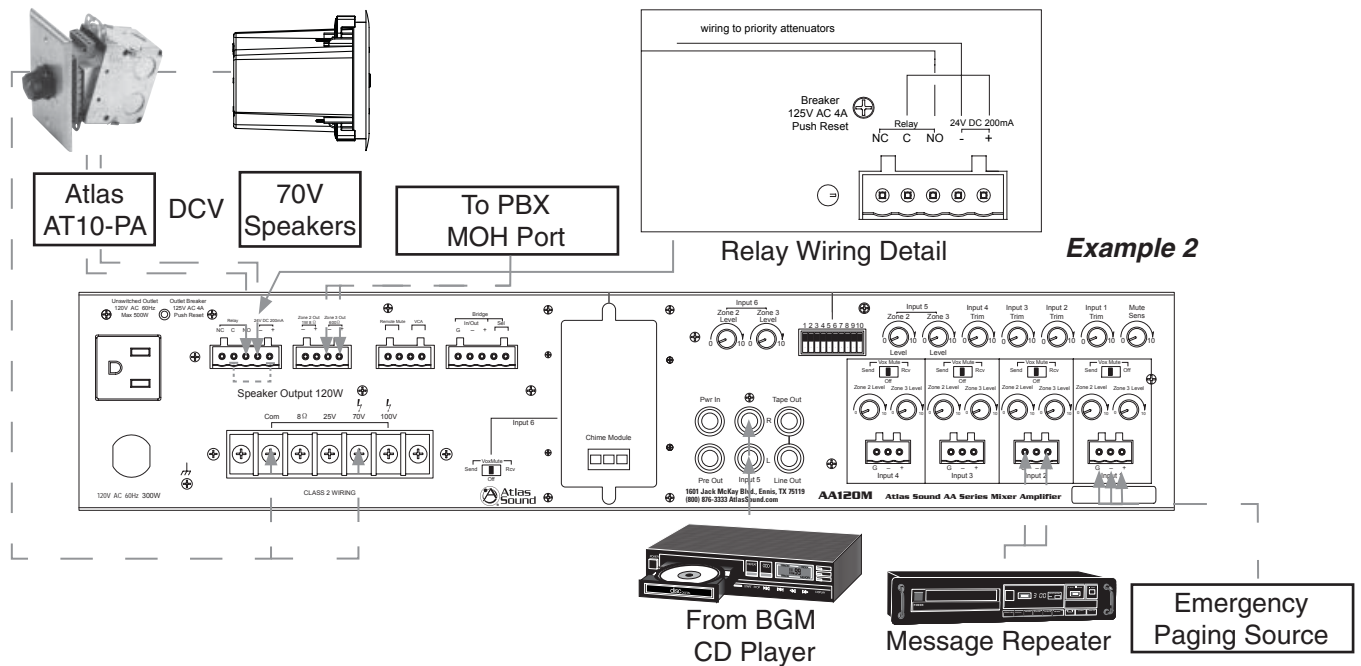

Specifications are subject to change without notice



AtlasSound.com

1601 JACK MCKAY BOULEVARD ENNIS, TEXAS 75119 U.S.A. • TELEPHONE: (800) 876-3333 • FAX: (800) 765-3435  
©2006 ATLAS SOUND LP Printed in U.S.A. 00106 AT5002179 RevA 01/06 PP



Example 3 - Optional Plug-In Module Application

The AA120M incorporates a module port that supports a variety of system options. For this example, a plug-in chime module is used to announce a request for building entry. The chime sound would only go to one speaker located over a security guard's area. In addition to the chime module, there is paging, background music, and message on hold connected.

- Connect the customer's PBX page port to INPUT 1. Note: The INPUT 1 Trim and Sens will need to be adjusted after all the settings and connections have been set.
- Set Dipswitch 10 to the "LINE" position.
- Set INPUT 1 to Mute Send.
- Connect the telephone message repeater to INPUT 2.
- Set INPUT 2 to Mute OFF. Turn down INPUT 2 volume control so no audio will be present at the speaker terminal.
- Connect Zone 3 to the Telephone PBX MOH port. Adjust INPUT 2 Zone 3 Level as needed.
- Connect a BGM player to INPUT 5. Note: The input gain of this channel may need to be changed for proper level balance. Dipswitch 6 allows you to select between a 100mV or 300mV input sensitivity.
- Install Chime Module to Input 6. Connect contact closure. Make sure front panel input level control is turned down.
- Adjust INPUT 6 Zone 2 Level as needed.
- Connect the Chime Speaker to Zone 2 output terminals.

Dipswitch Settings

- |                                   |  |
|-----------------------------------|--|
| Dipswitch 1 - OFF                 | Dipswitch 2 - OFF (Not affected)       |
| Dipswitch 3 - Depends on mic type | Dipswitch 4 - OFF                      |
| Dipswitch 5 - ON (Not affected)   | Dipswitch 6 - Set to the required gain |
| Dipswitch 7 - OFF                 | Dipswitch 8 - OFF                      |
| Dipswitch 9 - OFF (Line)          | Dipswitch 10 - OFF (Line/Tel)          |

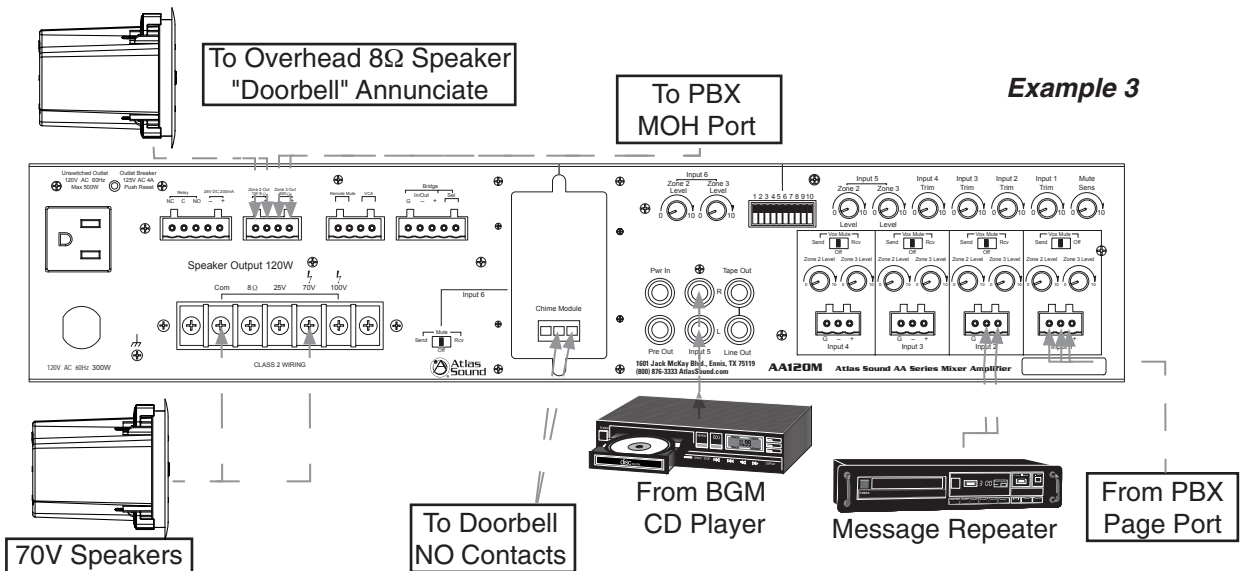

Specifications are subject to change without notice



AtlasSound.com

1601 JACK MCKAY BOULEVARD ENNIS, TEXAS 75119 U.S.A. • TELEPHONE: (800) 876-3333 • FAX: (800) 765-3435  
©2006 ATLAS SOUND LP Printed in U.S.A. 00106 AT5002179 RevA 01/06 PP



Example 4 - Remote Level Control

Utilizing the optional plug-in modules and the Atlas Sound wall mounted VCA attenuators, we can produce a conference room or hotel ballroom PA system with both remote Master and remote Background Music (BGM) volume controls. Inputs 1-4 are wired to the microphone wall plates in the room and the BGM comes from a CD player or Satellite radio receiver.

- Connect the mics to INPUTS 1-4. Note: The INPUT 1 Trim and Sens will need to be adjusted after all the settings and connections have been set. Dipswitch 3 (Phantom power) has been turned on for condenser type microphones.
- Dipswitches 7-10 have been set to "Mic".
- One wall mount volume control (Atlas Sound p/n AAVCC-10K) has been connected to the terminals marked "VCA" and Dipswitch 2 is set for Master.
- Optional plug-in module, Atlas p/n AS-ML, has been inserted into the rear module slot, and the BGM source has been plugged into the module's line level inputs. Adjust the module's trim control as needed. The AS-ML is a mic or line input module with VCA capabilities.
- Another volume control (AAVCC-10K) has been wired into the VCA terminals on the MODULE. This control will vary the BGM ONLY.

Dipswitch Settings

- |                            |                            |
|----------------------------|----------------------------|
| Dipswitch 1 - OFF          | Dipswitch 2 - OFF (Master) |
| Dipswitch 3 - ON           | Dipswitch 4 - OFF (CC)     |
| Dipswitch 5 - ON (Amp Dir) | Dipswitch 6 - Off (100mV)  |
| Dipswitch 7 - ON (Mic)     | Dipswitch 8 - ON (Mic)     |
| Dipswitch 9 - ON (Mic)     | Dipswitch 10 - ON (Mic)    |

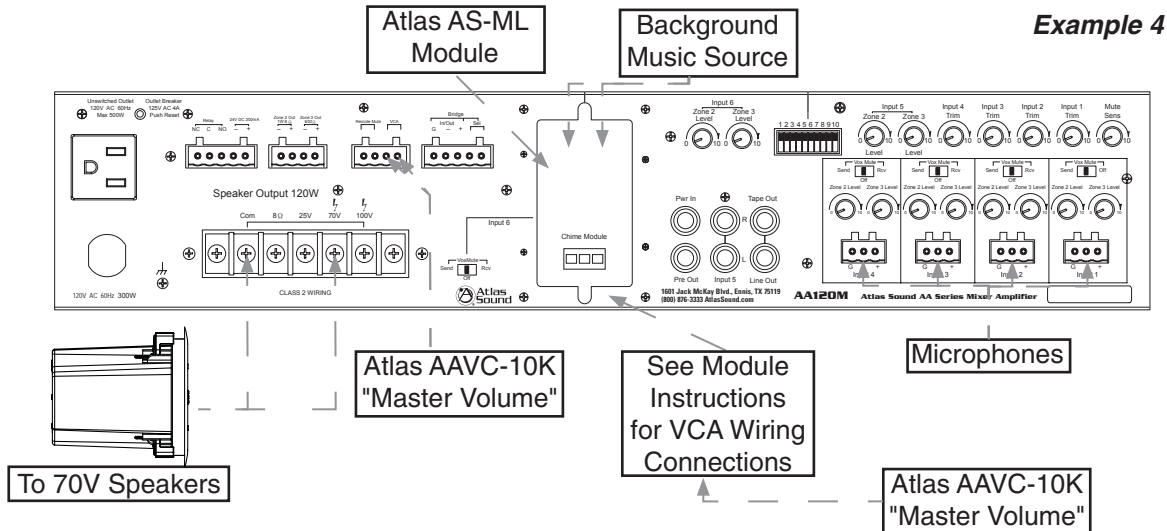

Specifications are subject to change without notice



AtlasSound.com

1601 JACK MCKAY BOULEVARD ENNIS, TEXAS 75119 U.S.A. • TELEPHONE: (800) 876-3333 • FAX: (800) 765-3435

©2006 ATLAS SOUND LP

Printed in U.S.A.

00106

ATS002179 RevA 01/06



**Example 5 - Hotel Room Combining Using Two AA120Ms**

This example utilizes the combining feature of the Atlas AA120M mixer amplifiers. The drawing on the following page shows the equipment connections for two hotel ballrooms, separated by a moveable air wall. They hotel needs to be able to have the audio system operate has one large unit (air wall open) or two discreet systems (air wall closed). As indicated in the example, a BGM CD player is shared between the two AA120Ms, via a "Y" cable, connected to input 5 of each mixer amp. The Bridge terminals of both amplifiers are connected together, through a DPST switch that makes (combines) or breaks (separates) the Bridge connections between the amplifiers. When the switch is closed, any audio signal into either amp will be present at both amplifier's speaker outputs. A volume control and DPST switch (see drawing for clarity) controls the room audio level and turns the music on or off in each room. For emergency evacuation purposes, a signal from the hotel's fire alarm system is connected to channel 1 of both amplifiers, with both channel's mute sensitivity adjusted as needed. To mute all audio when the emergency signal is present, all other channels are set for Mute receive.

- Set Input 1 to Mute Send
- Set Input 2-4 to Mute RCV

**Dipswitch Settings**

- Dipswitch 1 - Off
- Dipswitch 3 - Off
- Dipswitch 5 - Off (Not Affected)
- Dipswitch 7 - On (Mic)
- Dipswitch 9 - On (Mic)

- Dipswitch 2 - Off (Master)
- Dipswitch 4 - Off (Not Affected)
- Dipswitch 6 - Set to required gain
- Dipswitch 8 - On (Mic)
- Dipswitch 10 - Off (Tel/Line)

*Specifications are subject to change without notice*



**AtlasSound.com**



Example 5 - Hotel Room Combining Using Two AA120Ms

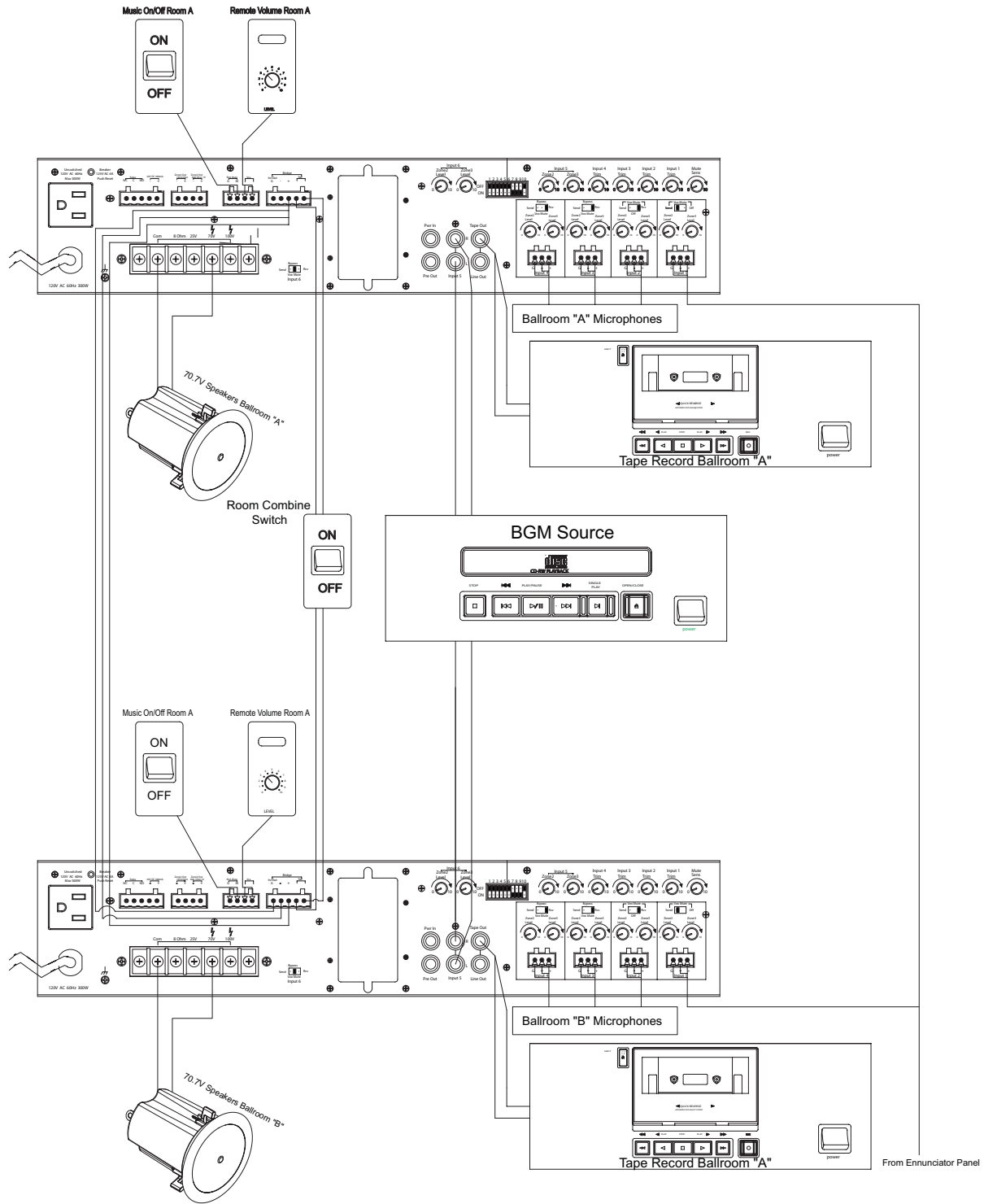

Specifications are subject to change without notice



AtlasSound.com

1601 JACK MCKAY BOULEVARD ENNIS, TEXAS 75119 U.S.A. • TELEPHONE: (800) 876-3333 • FAX: (800) 765-3435

©2006 ATLAS SOUND LP

Printed in U.S.A.

00106

ATS002179 RevA 01/06

PP



WIRING THE AA120M

**Speaker Outputs** - Use 2 conductor unshielded wire of the appropriate gauge. If you are unsure about this, contact Atlas Sound Tech Support at 1-800-876-3333. Make sure you know how many speakers you need and what tap value you intend to use.

**Mic/Line Input** - Use 2 conductor w/ shield for low level signals of 20-22 gauge is best. Maintain the proper polarity, + to +, - to -, and shield to ground. For unbalanced signals, connect the (G) to the (-) terminal.

**Unbalanced Inputs and Outputs** - Pre-made RCA cables can be purchased from vendors to simplify interconnection to external devices.

**Zone 2 Out** - Use 2 conductor, 20-22 gauge, shielded is best. Terminate the shield at the input to the device if possible.

Security Plug Installation

SECURITY COVER OPTION

In order to prevent unauthorized operation of the AA120M, optional security covers are available which take the place of the front panel knobs. After the AA120M has been installed and is operating as desired, grasp the front panel knobs and pull straight out from the front panel. Replace the knobs with security covers, Atlas Sound part number AAVCC-5, available in quantities of 5.

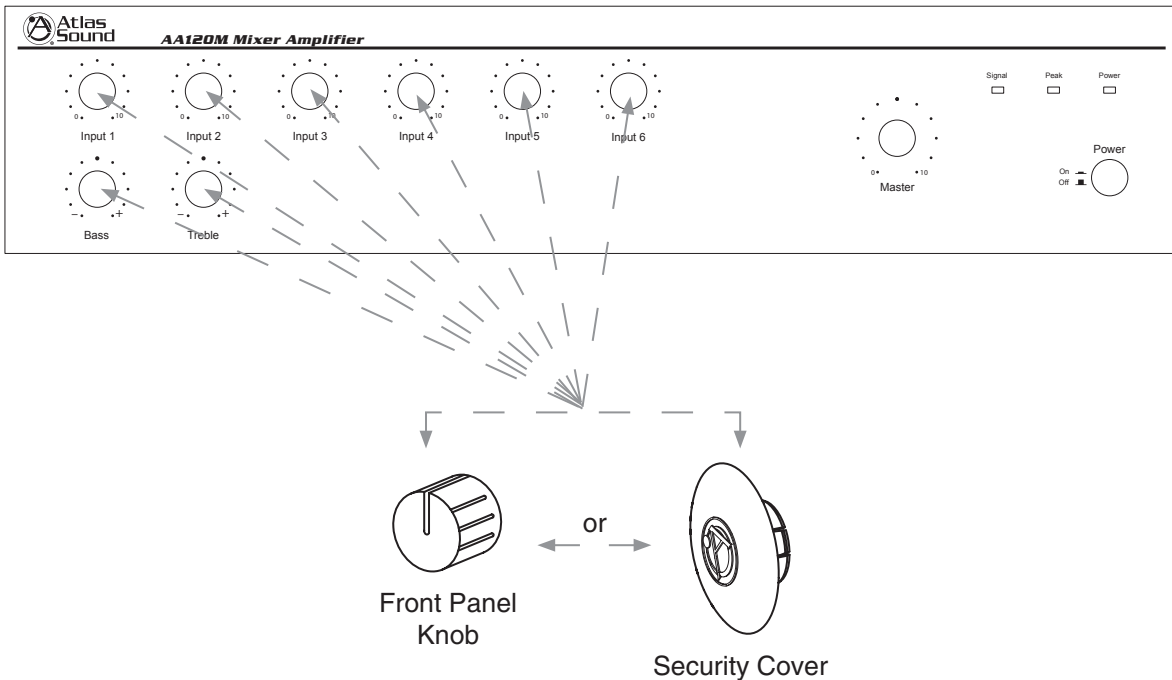

Specifications are subject to change without notice



AtlasSound.com

1601 JACK MCKAY BOULEVARD ENNIS, TEXAS 75119 U.S.A. • TELEPHONE: (800) 876-3333 • FAX: (800) 765-3435  
©2006 ATLAS SOUND LP Printed in U.S.A. 00106 AT5002179 RevA 01/06 PP



### WIRING THE AAVCC-10K VCA POTENTIOMETER

Atlas Sound part number AAVCC-10K consists of a single gang "Decora" style wall plate with a pre-mounted 10k potentiometer and knob.

Use two conductor unshielded wire connecting the pot terminals to the terminals marked "VCA" on the back of the amp.

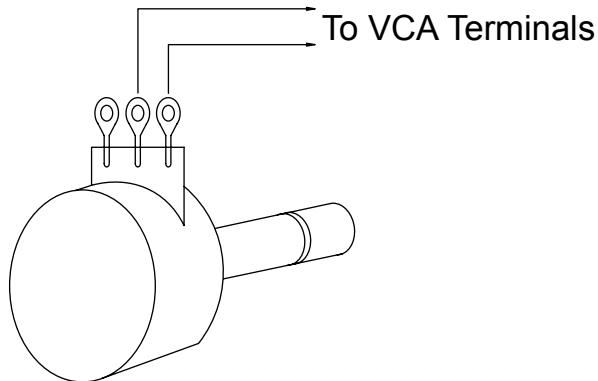

### RACK MOUNT KIT

For permanent mounting of the AA120M into equipment racks, order part number AARM-2RU. If multiple units are being rack mounted, install Atlas 1RU (SVP19-1-052) vented panels between amplifiers in order to aid cooling.

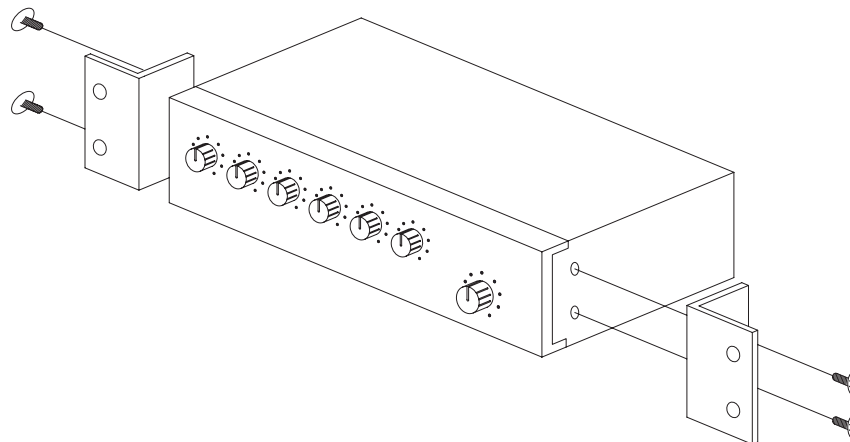

Rack Ear Installation

*Specifications are subject to change without notice*



**AtlasSound.com**



INTERNAL JUMPER LOCATIONS



WARNING

Remove the power cord from the wall before proceeding as hazardous voltages are present inside the AA120M.

1. Disconnect the power cord from the wall socket.
2. Remove the screws securing the top cover of the AA120M, and remove the cover.
3. Refer to circuit board layout in the diagram below to locate the jumpers.
4. Configure the jumpers to suit your application.
5. Replace top cover and secure using the screws removed in step 2.
6. Re-install the power cord and test the configuration.

If you have questions or need assistance with your specific application, contact Atlas Sound Tech Support at 1-800-876-3333.

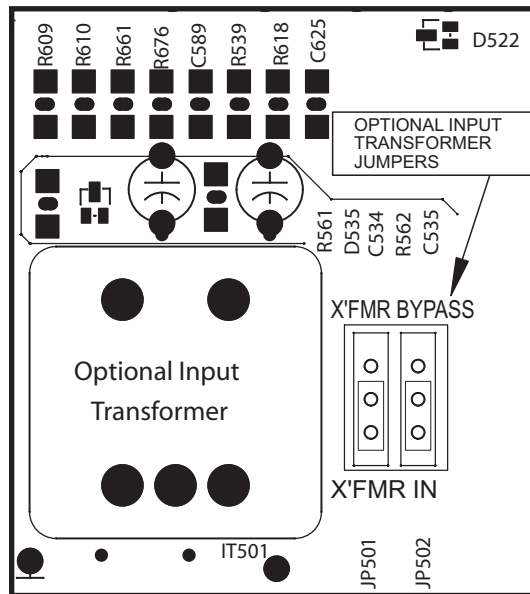

XFMR location on MAIN PCB

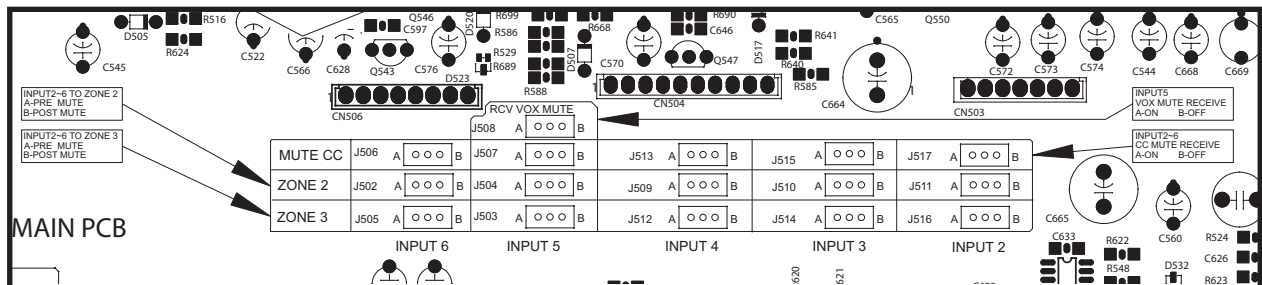

Jumper locations on MAIN PCB

Specifications are subject to change without notice



AtlasSound.com

1601 JACK MCKAY BOULEVARD ENNIS, TEXAS 75119 U.S.A. • TELEPHONE: (800) 876-3333 • FAX: (800) 765-3435

©2006 ATLAS SOUND LP

Printed in U.S.A.

00106

ATS002179 RevA 01/06

PP



BLOCK DIAGRAM FOR AA120M

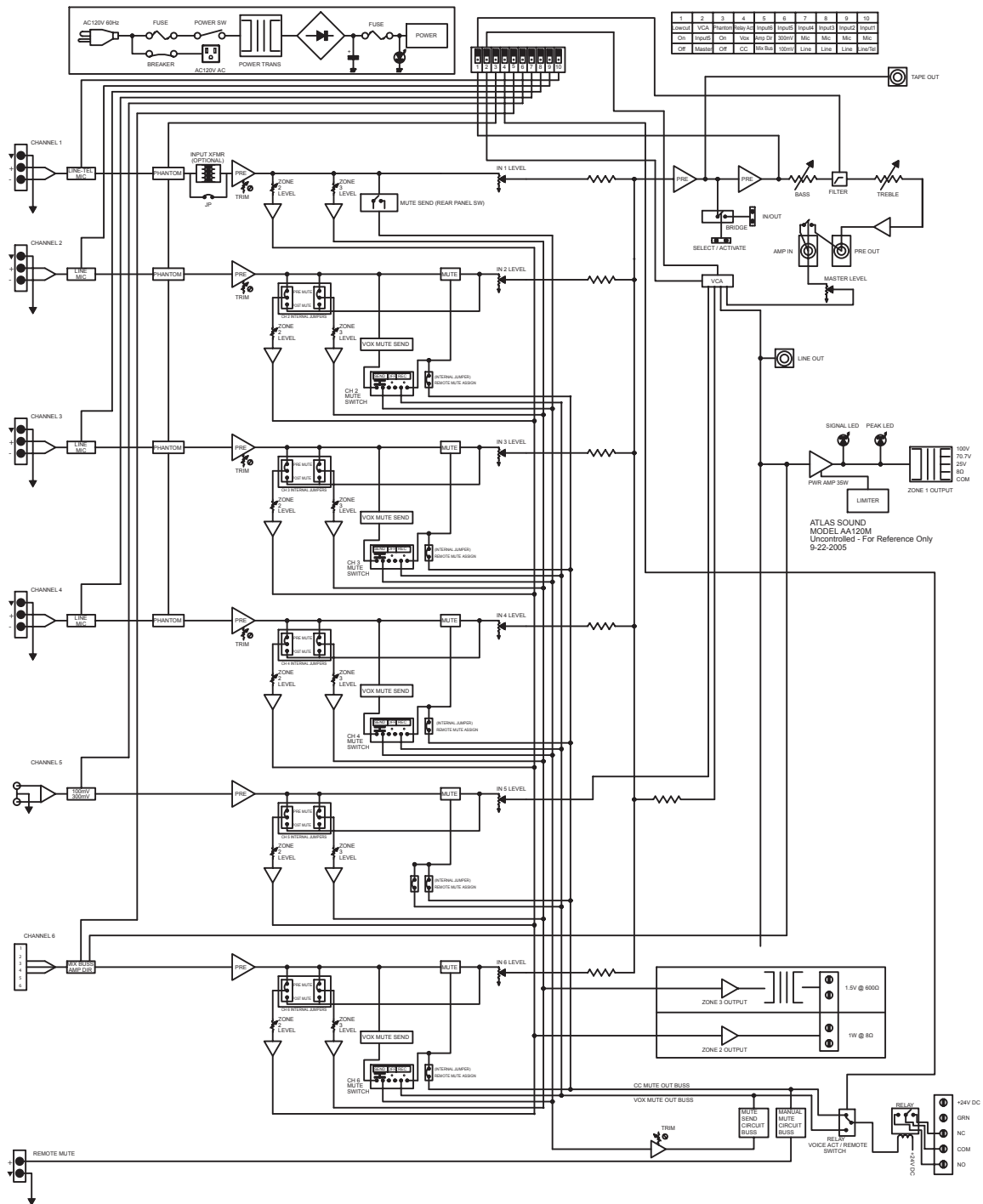

Specifications are subject to change without notice



AtlasSound.com

1601 JACK MCKAY BOULEVARD ENNIS, TEXAS 75119 U.S.A. • TELEPHONE: (800) 876-3333 • FAX: (800) 765-3435

©2006 ATLAS SOUND LP

Printed in U.S.A.

00106

ATS002179 Rev A 01/06

PP



**SPECIFICATIONS**

<b>POWER OUTPUT</b>	
Max. Average Power @ 50Hz-20kHz with .5% THD (10-80kHz filter) 8 Ohm, 1kHz, 120W RMS	
<b>TRANSFORMER OUTPUTS</b>	
25V	120W RMS
70V	120W RMS
100V	120W RMS
<b>FREQUENCY RESPONSE</b>	
50Hz-20kHz ±3dB	
<b>DISTORTION</b>	
<1% at rated power	
<b>SENSITIVITY</b>	
Input 1	Line 316mV (-10dBV) 10k Ohm
	Mic .316mV~3.16mV (-50dBV~ -70dBV)
Inputs 2-4	Line 100mV (-20dBV) 10k Ohm
	Mic .316mV~3.16mV (-50dBV~ -70dBV)
Input 5	Line 316mV/100mV (-10dBV/-20dBV) Selectable
Input 6	Module Input
<b>OUTPUTS</b>	
Main:	Transformer coupled, balanced, 8Ω, 25V, and 70V
Zone 2- 8Ω	Unbalanced 1W
Zone 2- 600Ω	Balanced 1.5V
<b>OUTPUT REGULATION</b>	
Less than 2dB, no load to full load	
<b>SIGNAL TO NOISE RATIO</b>	
Input 1-4	>55dB
Input 5	>75dB
<b>TONE CONTROLS</b>	
Bass	±10dB @ 100Hz
Treble	±10dB @ 10kHz
<b>INDICATORS</b>	
Power, signal, peak	
<b>POWER CONSUMPTION</b>	
300 Watts	
<b>DIMENSIONS</b>	
16.54"W x 4.24"H x 13.84"D (420mm x 107.7mm x 351.5mm)	
<b>WEIGHT</b>	
26.75 lbs (12.16kg)	

*Specifications are subject to change without notice*



**AtlasSound.com**

1601 JACK MCKAY BOULEVARD ENNIS, TEXAS 75119 U.S.A. • TELEPHONE: (800) 876-3333 • FAX: (800) 765-3435

©2006 ATLAS SOUND LP

Printed in U.S.A.

00106

ATS002179 RevA 01/06

PP



NOTES: \_\_\_\_\_

\_\_\_\_\_

\_\_\_\_\_

\_\_\_\_\_

\_\_\_\_\_

\_\_\_\_\_

\_\_\_\_\_

\_\_\_\_\_

\_\_\_\_\_

\_\_\_\_\_

\_\_\_\_\_

\_\_\_\_\_

\_\_\_\_\_

\_\_\_\_\_

\_\_\_\_\_

\_\_\_\_\_

\_\_\_\_\_

\_\_\_\_\_

\_\_\_\_\_

\_\_\_\_\_

\_\_\_\_\_

*Specifications are subject to change without notice*



**AtlasSound.com**





### Limited Warranty

All products manufactured by Atlas Sound are warranted to the original dealer/installer, industrial or commercial purchaser to be free from defects in material and workmanship and to be in compliance with our published specifications, if any. This warranty shall extend from the date of purchase for a period of three years on all Atlas Sound products, including SOUNDOLIER brand, and ATLAS SOUND brand products except as follows: one year on electronics and control systems; one year on replacement parts; and one year on Musician Series stands and related accessories. Additionally, fuses and lamps carry no warranty. Atlas Sound will solely at its discretion, replace at no charge or repair free of charge defective parts or products when the product has been applied and used in accordance with our published operation and installation instructions. We will not be responsible for defects caused by improper storage, misuse (including failure to provide reasonable and necessary maintenance), accident, abnormal atmospheres, water immersion, lightning discharge, or malfunctions when products have been modified or operated in excess of rated power, altered, serviced or installed in other than a workman like manner. The original sales invoice should be retained as evidence of purchase under the terms of this warranty. All warranty returns must comply with our returns policy set forth below. When products returned to Atlas Sound do not qualify for repair or replacement under our warranty, repairs may be performed at prevailing costs for material and labor unless there is included with the returned product(s) a written request for an estimate of repair costs before any nonwarranty work is performed. In the event of replacement or upon completion of repairs, return shipment will be made with the transportation charges collect.

EXCEPT TO THE EXTENT THAT APPLICABLE LAW PREVENTS THE LIMITATION OF CONSEQUENTIAL DAMAGES FOR PERSONAL INJURY, ATLAS SOUND SHALL NOT BE LIABLE IN TORT OR CONTRACT FOR ANY DIRECT, CONSEQUENTIAL OR INCIDENTAL LOSS OR DAMAGE ARISING OUT OF THE INSTALLATION, USE OR INABILITY TO USE THE PRODUCTS. THE ABOVE WARRANTY IS IN LIEU OF ALL OTHER WARRANTIES INCLUDING BUT NOT LIMITED TO WARRANTIES OF MERCHANTABILITY AND FITNESS FOR A PARTICULAR PURPOSE.

Atlas Sound does not assume, or does it authorize any other person to assume or extend on its behalf, any other warranty, obligation, or liability. This warranty gives you specific legal rights and you may have other rights which vary from state to state.

### SERVICE

Should your AA Series amplifier require service, please contact the Atlas Sound warranty department at 1-866-689-8055, ext. 277 to obtain an RA number.

Atlas Sound Tech Support can be reached at 1-800-876-3333.

Visit our website at [www.AtlasSound.com](http://www.AtlasSound.com) to see other Atlas products.

*Specifications are subject to change without notice*



**AtlasSound.com**