



AH5040S

15" 2-Way Stadium Horn System 50° x 40°



AH5040S

Features

- Efficiency rating of 104 dB (1 W/1 M)
- 250 watts power handling
- Maximum output of 128 dB (Rated Power @ 1 M)
- Constant directivity design offers controlled coverage of 50° horizontal by 40° vertical (2 kHz octave band)
- Excellent low frequency response down to 80 Hz (-5 dB) provides bass you can feel
- Driver compliment includes a 15" cast frame woofer with a concentrically mounted 1" exit compression driver coupled to a 50° H x 40° V HF horn
- Full range frequency response of 75 Hz – 17 kHz (± 5 dB)
- Easy, weather resistant connection via parallel 4 pole terminal strip
- 8 Ω nominal system impedance (70.7V operation via optional Atlas Sound model AF140 transformer)
- Heavy duty stainless steel mounting bracket (included) allows for easy installation to most any flat surface
- Three forged eyebolts also included for suspended installation

Applications

Atlas Sound model AH5040S stadium horn is ideal for directional sound distribution where full range reproduction, maximum intelligibility, and high sound pressure levels are required. Applications include football stadiums, sports arenas, baseball fields, convention centers, and auditoriums.

Weather resistant construction features of the AH5040S include a multiple screen configuration to prevent moisture from damaging internal components.

A perforated aluminum screen covers the large horn mouth, a secondary screen is in place forward of the high frequency driver, and a third tightly perforated screen protects the 15" cast frame woofer.

Installation

A heavy-duty stainless steel "C" style mounting bracket is included with the AH5040S to allow easy mounting to most any flat surface. Three drop forge eyebolts are also pre-installed (2-front of horn plus 1-rear for "pull-up") for suspension mounting via load rated wire rope. (Use caution when suspending any object overhead. Refer to installation manual for more details).

The AH5040S includes a parallel wired, weather resistant 4 pole terminal block connector on the underside of the device for easy hook-up and daisy chain wiring to other AH5040S's. If 70.7V/100V operation is required the optional Atlas Sound AF140 autoformer may be used. NOTE: Due to the full range operation capabilities of the AH5040S 70.7V/100V operation although possible, is discouraged. Better frequency response and amplifier dampening factor can be realized by using large gauge (#10 to #12) home runs and series/parallel hook-up wiring at the head end location with direct coupled, low impedance amplifiers. Generally speaking, this improvement of frequency response and amplifier dampening factor is worth the sacrifice of line loss over distance - especially if transformer insertion loss at the loudspeaker location is considered.



AH5040S

Technical Specifications

Power Rating:	250 watts (45V) RMS 350 watts (53V) Peak
Sensitivity (1 W / 1 M):	104 dB SPL (70 Hz – 17 kHz ½ octave bands)
Frequency Response:	75 Hz - 17 kHz (±5 dB) Dispersion: 50° x 40°
Impedance:	8 Ω Nominal
Minimum Impedance:	5.6 Ω @ 9000 Hz Nominal -6 dB Minimum
Height:	23.75" (603.25 mm)
Width:	21.41" (543.81 mm)
Depth:	30.07" (763.78 mm)
Shipping Weight:	125 lbs (56.7 kg)
Driver Type:	1" HF & 15" LF

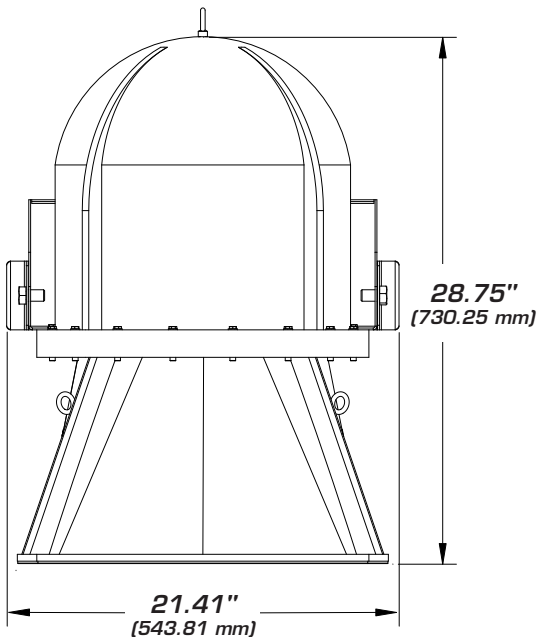
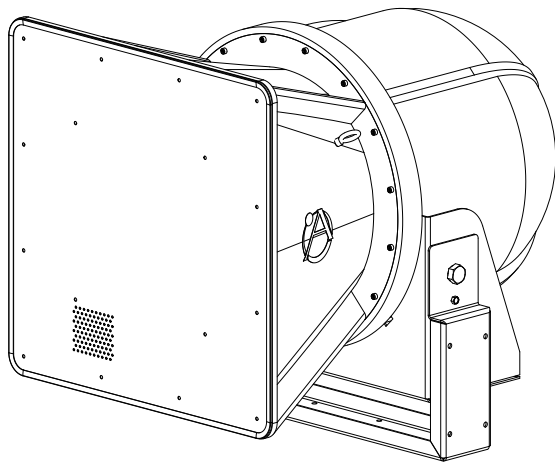

Architect & Engineer Specifications

Loudspeaker shall be Atlas Sound Model AH5040S or approved equal.

Loudspeaker shall be a 2-way design incorporating an environment-resistant housing.

Loudspeaker shall include a 15", horn loaded, cast frame woofer housed in a 2296 cubic inch (1.3 feet³) enclosure and an integral, concentrically mounted 1" exit compression driver coupled to a constant directivity high frequency horn. The three pole (18 dB/octave) dividing network crossover frequency shall be 1.4 kHz. The dividing network shall include a poly switch protection circuit for the high-frequency component.

The loudspeaker system shall be capable of providing a sound dispersion angle of 50° horizontal by 40° vertical in the 2 kHz octave band.

Rated power shall be 250 watts based on EIA Standard RS-426B*

Enclosure shall be UV-resistant, steel reinforced, low pressure injection molded fiberglass and shall include a 3 stage multiple mesh filter system for weather and rodent resistance:

- A. Large 20-gauge perforated aluminum screen on front mouth assembly.
- B. 100 x 100 weave stainless steel mesh between HF horn and HF driver.
- C. 100 x 100 weave stainless steel mesh over 15" woofer.

Sensitivity shall be 104 dB SPL (75 Hz to 17 kHz ½ octave bands) measured at a distance of one meter on axis with a one watt input.

Overall frequency response shall be 75 Hz to 17 kHz (± 5 dB).

The loudspeaker shall include a stamped and formed, 12-gauge stainless steel mounting bracket assembly for surface mounting and three M8 drop forged eyebolts for suspension mounting.

The input section located on the bottom rear of the loudspeaker shall include a parallel wired 4 pole terminal block connector (1+ & 1- to input, 2+ & 2- provided as a through connection)

Nominal impedance shall be 8 Ω.

Dimensions shall be: Height: 23.75" (603.25 mm)
Width: 21.41" (543.81 mm)
Depth: 30.07" (763.78 mm)
Weight: 125 lbs (56.7 kg)

*EIA test spectrum is applied for eight hours.
(This procedure provides a rigorous test of both thermal and mechanical failure modes.)

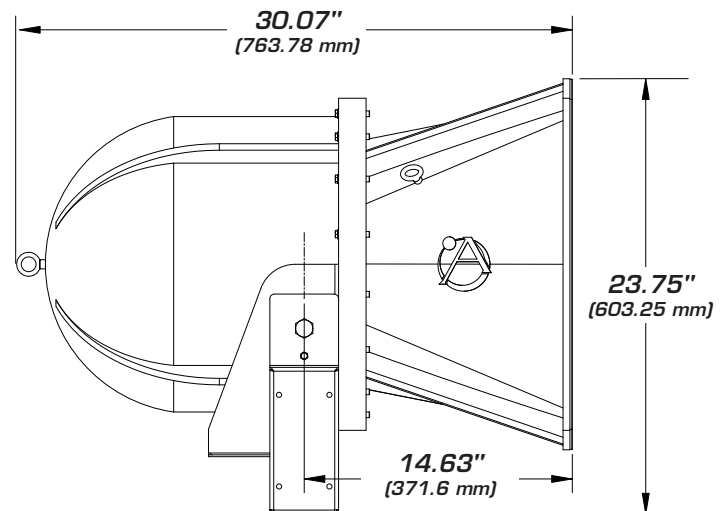

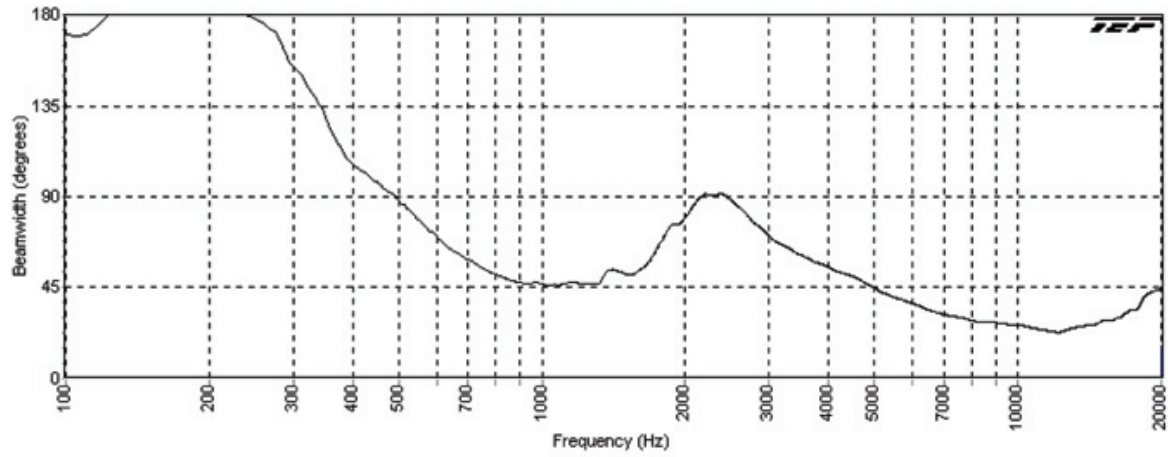

AH5040S Horizontal Beamwidth (-6 dB)

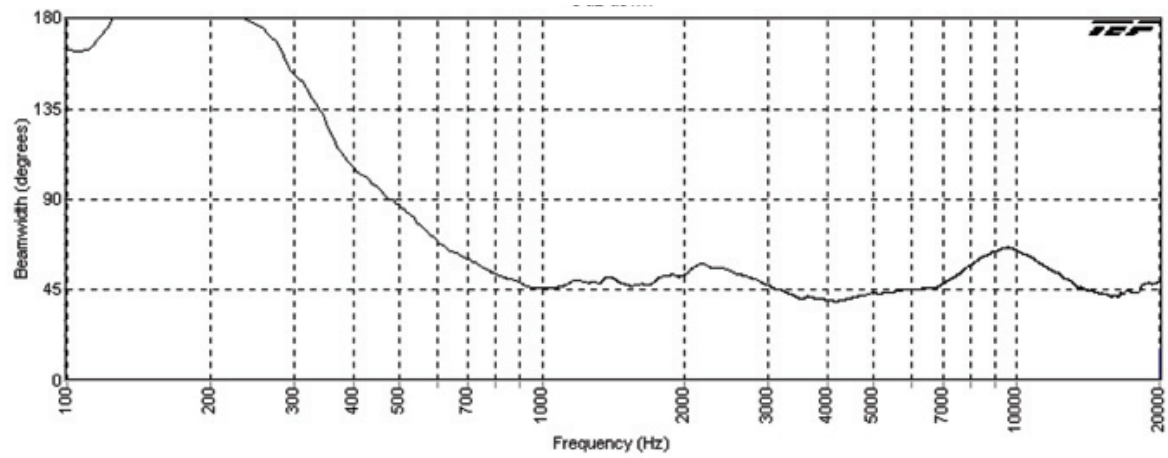

AH5040S Vertical Beamwidth (-6 dB)

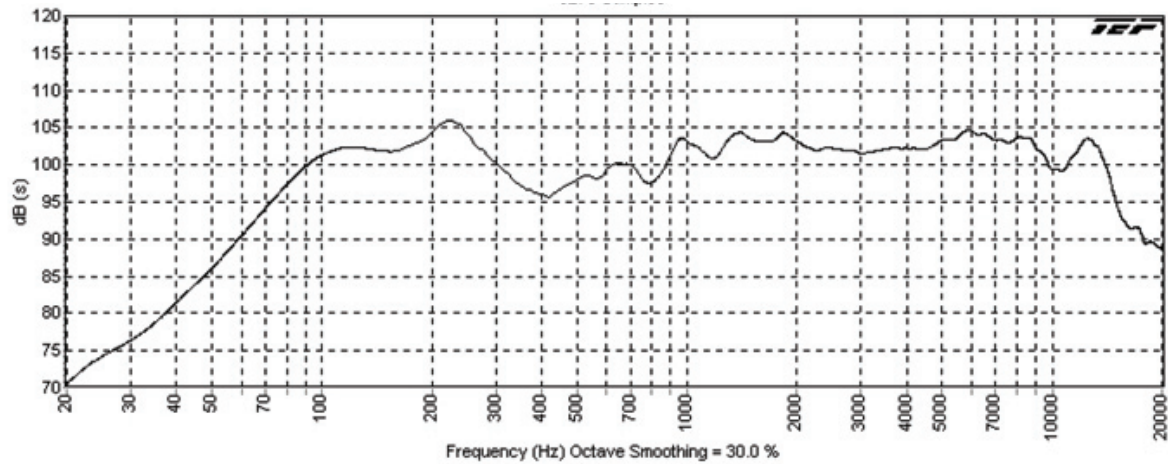

AH5040S Frequency Response

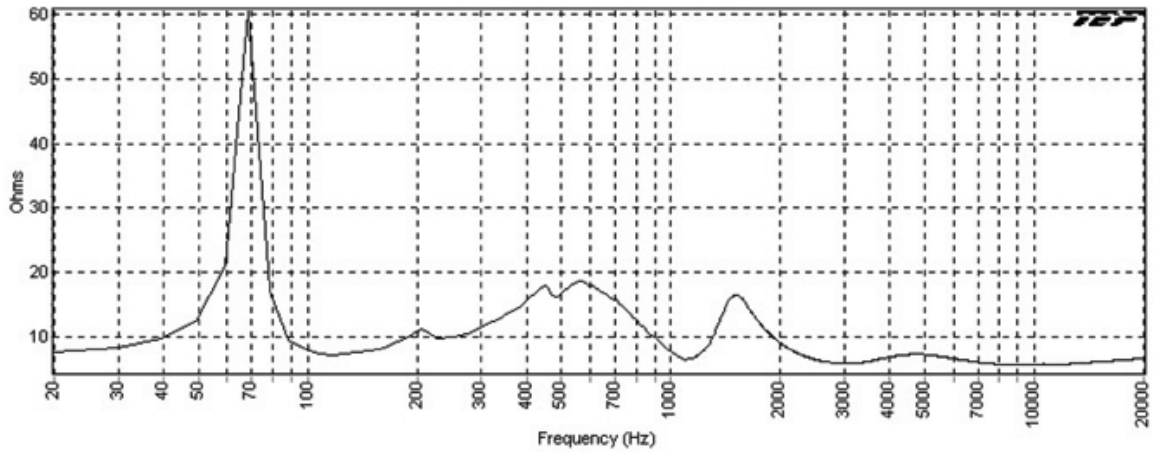

AH5040S Impedance (ohms) vs. Frequency

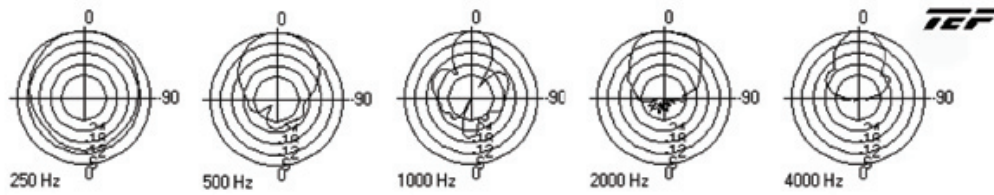

AH5040S Horizontal Polars (Normalized to Zero on Axis) (-6 dB)

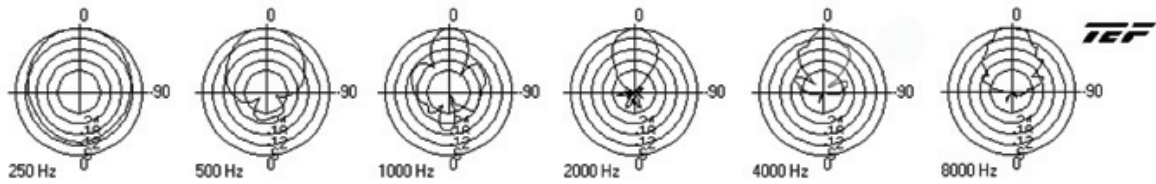

AH5040S Vertical Polars (Normalized to Zero on Axis) (-6 dB)