



# AH6565S

15" 2-way Stadium Horn System 65° x 65°



**AH6565S**

## Features

- Efficiency rating of 102 dB (1 W / 1 M)
- 250 watts power handling
- Maximum output of 126 dB (Rated Power @ 1 M)
- Constant Directivity design offers controlled coverage of 65° H by 65° V (2 kHz octave band)
- Excellent low frequency response provides bass you can feel
- Driver complement includes a 15" cast frame woofer with a concentrically mounted 1" exit compression driver coupled to a 65° H x 65° V HF horn
- Full range frequency response of 75 Hz – 14.5 kHz ( $\pm 5$  dB)
- Easy, weather resistant connection via 4-pole terminal block connector
- 8  $\Omega$  nominal system impedance (70.7V / 100V operation via optional Atlas Sound model AF140 transformer)
- Heavy duty stainless steel mounting bracket (included) allows for easy installation to most any flat surface
- Three forged eyebolts also included for suspended installation

## Applications

Atlas Sound model AH6565S stadium horn, with its square coverage pattern, is ideal for down firing applications like convention centers where full range reproduction, maximum intelligibility, and high sound pressure levels are required. Other applications include football stadiums, sports arenas, baseball fields, convention centers, and auditoriums.

Weather resistant construction features of the AH6565S include a multiple screen configuration to prevent moisture from damaging internal components: A perforated aluminum screen covers the large horn mouth, a secondary screen is in place forward of the high frequency driver, and a third tightly perforated screen protects the 15" cast frame woofer.

## Installation

A heavy-duty stainless steel "C" style mounting bracket is included with the AH6565S to allow easy mounting to almost any flat surface. Three drop forge eyebolts are also pre-installed (2-front of horn plus 1-rear for "pull-up") for suspension mounting via load rated aircraft cable. (Use caution when suspending any object overhead. Refer to the installation manual for more details.)

The AH6565S includes a 4 pole terminal block connector on the underside of the device for easy hook-up and daisy chain wiring to other AH6565S. If 70.7V/100V operation is required the optional Atlas Sound AF140 auto-former may be used.

NOTE: Due to the full range operation capabilities of the AH6565S, 70.7/100V operation is possible, but discouraged. Better frequency response and amplifier dampening factor can be realized by using large gauge (#10 to #12) home runs and series/parallel hook-up wiring at the head end location with direct coupled, low impedance amplifiers. Generally speaking, this improvement of frequency response and amplifier dampening factor is worth the sacrifice of line loss over distance - especially if transformer insertion loss at the loudspeaker location is considered.



**AH6565S**

## Technical Specifications

Power Rating:	250 watts (45V) RMS
Sensitivity 1W1M:	104 dB SPL (70 Hz – 17 kHz 1/3 octavebands)
Frequency Response:	75 Hz - 14.5 kHz ( $\pm 5$ dB)
Dispersion:	65° x 65°
Impedance:	8 $\Omega$ (Nominal)
Minimum Impedance:	5.6 $\Omega$ @ 9000 Hz Nominal -6 dB (Minimum)
Height:	23.75" (603.25 mm)
Width:	21.41" (543.81 mm)
Depth:	30.08" (764.03 mm)
Shipping Weight:	125 lbs (56.7 kg)
Driver Type:	1" HF and 15" LF

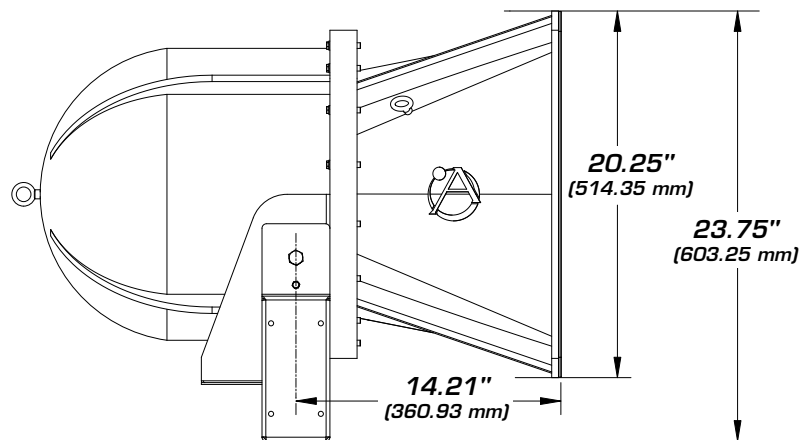
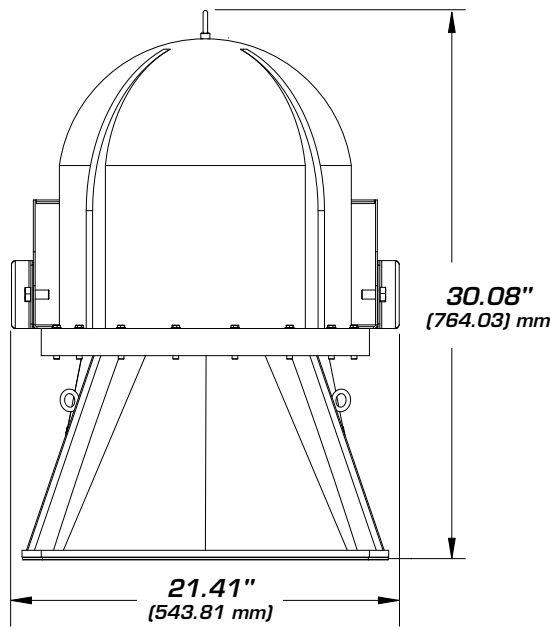
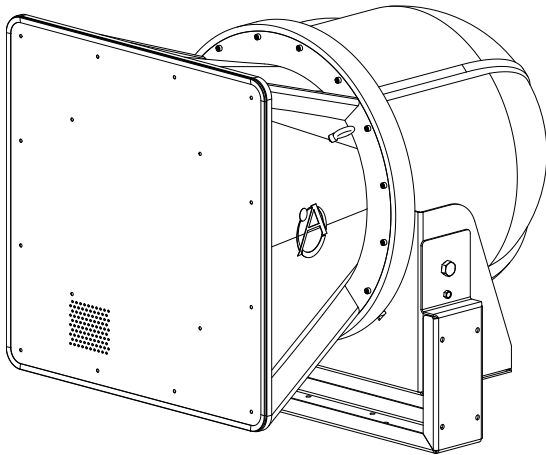

## Architect & Engineer Specifications

Loudspeaker shall be Atlas Sound Model AH6565S or approved equal.

Loudspeaker shall be a 2-way design incorporating an environment-resistant housing.

Loudspeaker shall include a 15", horn loaded, cast frame woofer housed in a 2296 in<sup>3</sup> (1.3 cubic feet) enclosure and an integral, concentrically mounted 1" exit compression driver coupled to a constant directivity high frequency horn. The three pole (18 dB/octave) dividing network cross-over frequency shall be 1.4 kHz. The dividing network shall include a poly switch protection circuit for the high-frequency component.

The loudspeaker system shall be capable of providing a sound dispersion angle of 65° horizontal by 65° vertical in the 2 kHz octave band.

Rated power shall be 250 watts based on EIA Standard RS-426B\*

Enclosure shall be UV-resistant, steel reinforced, low pressure injection molded fiberglass and shall include a 3 stage multiple mesh filter system for weather and rodent resistance:

- A. Large 20-gauge perforated aluminum screen on front mouth assembly.
- B. 100 x 100 weave stainless steel mesh between HF horn and HF driver.
- C. 100 x 100 weave stainless steel mesh over 15" woofer.

Sensitivity shall be 102 dB SPL (70 Hz – 14.5 kHz 1/3 octave bands) measured at a distance of one meter on axis with a one watt input.

Overall frequency response shall be 75 Hz – 14.5 kHz (  $\pm 5$  dB).

The loudspeaker shall include a stamped and formed, 12-gauge stainless steel mounting bracket assembly for surface mounting and three M8 drop forged eyebolts for suspension mounting.

The input section located on the bottom rear of the loudspeaker shall include a 4 pole terminal block connector.

Nominal impedance shall be 8  $\Omega$ .

Dimensions shall be: Height 23.75" (603.25 mm)  
Width 21.41" (543.81 mm)  
Depth 30.08" (764.03 mm)  
Weight 125 lbs (56.7 kg)

\*EIA test spectrum is applied for eight hours. (This procedure provides a rigorous test of both thermal and mechanical failure modes.)

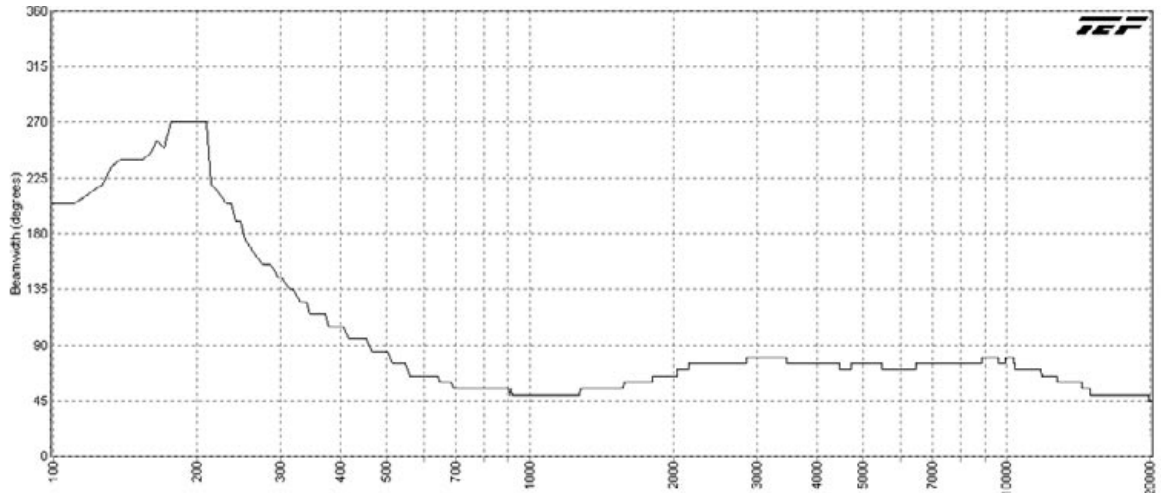

AH6565S Horizontal Beamwidth (-6 dB)

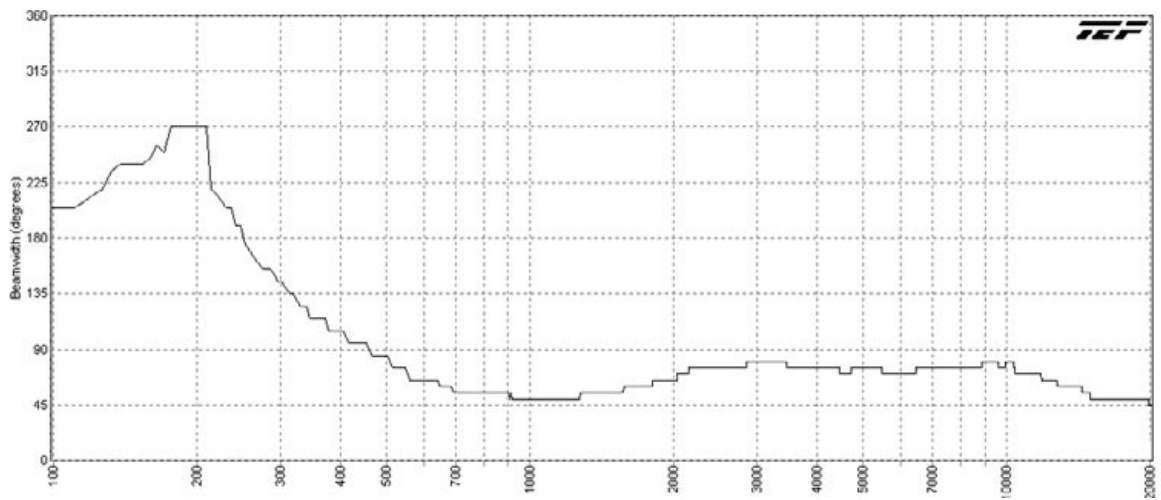

AH6565S Vertical Beamwidth (-6 dB)

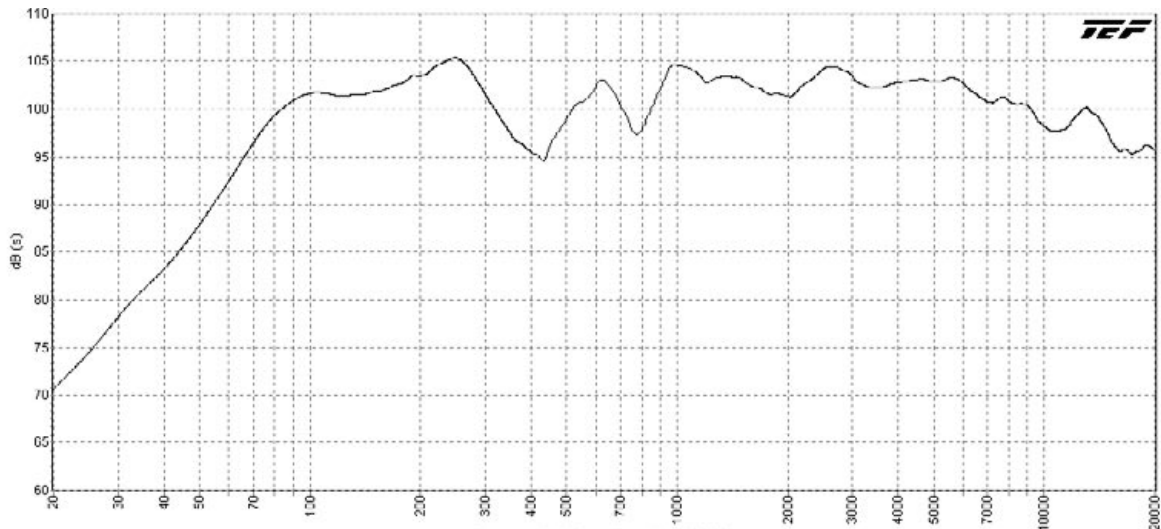

AH6565S Frequency Response

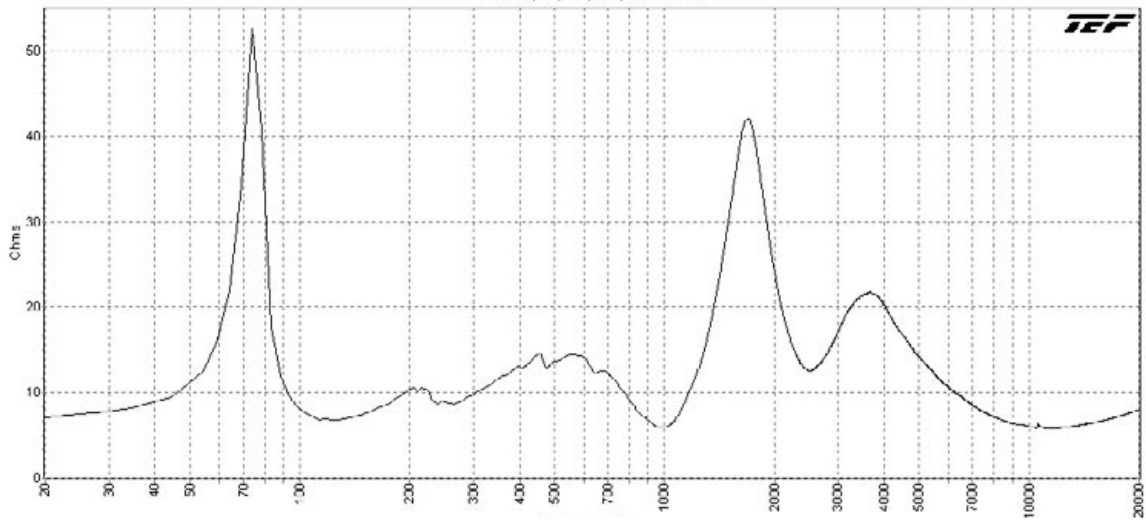

AH6565S Impedance (ohms) vs. Frequency

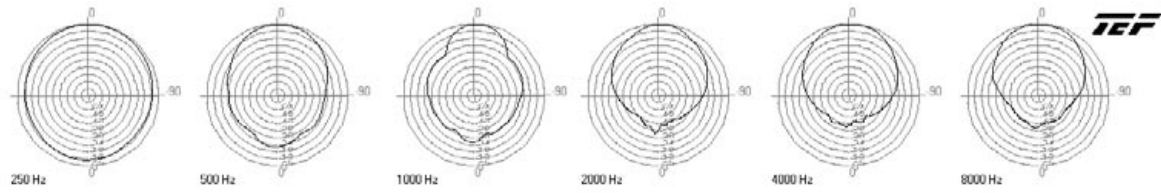

AH6565S Horizontal Polars (Normalized to Zero On Axis) (-6 dB)

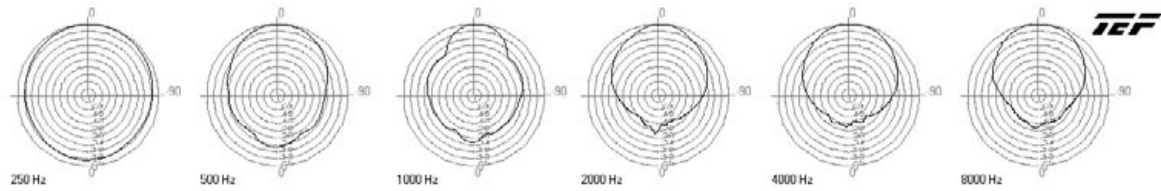

AH6565S Vertical Polars (Normalized to Zero On Axis) (-6 dB)