

AT-MX341a SmartMixer®

Four-channel Automatic Microphone Mixer



Installation and Operation



Contents

Introduction	3
What is the SmartMixer?	3
Features	3
Front Panel	4
Rear Panel	5
Installation and Setup	6
Priority Microphones and Lockout Bus	6
Preamplifier Gain	7
Output Gain	7
Phantom Power	7
Output Level LED Meter	8
Adjusting "Off" Attenuation	8
Control Voltage Out	9
Daisy-chaining Mixers	10
Rack Mounting	10
Security Caps	10
Specifications	11
Warranty	12

Introduction

Please Note!

This manual assumes use of microphone-level inputs and line-level output, the most typical SmartMixer application. However, all inputs and the output may be individually switched internally to achieve any combination of mic- and line-level input/output. See page 7 for details.

What is the SmartMixer?

The AT-MX341a SmartMixer® Automatic Microphone Mixer is a microprocessor controlled, automatic switching, four-channel microphone mixer.

The microphone inputs are XLRF-type balanced, with 12-volt phantom power available on pins 2 and 3. The output is XLRM-type balanced, non-inverting.

AT-MX341a mixers can be daisy-chained via the included AT8325/1.0 Link Cable and special connectors on the rear panel. The control bus and the audio are carried between mixers by the link cable. The result is that all microphones on a multi-mixer system can be controlled by one microphone connected to any mixer. Since all of the mixers are independently powered, there is no practical limit to the number of SmartMixers that can be daisy-chained.

Features

To custom-tailor conferencing needs, the mode of each microphone channel can be independently switched via the front panel “priority pre-select” DIP switches. The combination of switch settings results in three different modes of priority selection/operation.

In any of the three modes of automatic operation, when everyone stops talking, the last microphone “on” will remain “on.” In a teleconferencing, recording, or broadcast application, this feature will provide continuous room ambience. This feature is cascaded throughout all linked mixers so that only one microphone in the entire system will remain on.

Each input channel has an independent gain control on the front panel. Substantial gain reserve and adjustment range permits microphones of widely differing sensitivities to be used together successfully.

When a microphone is “off,” its input is only attenuated. This attenuation is factory set at 8 dB. The amount of “off” attenuation can be internally adjusted between 6 dB and 20 dB if desired. (See page 8, “Adjusting ‘Off’ Attenuation.”)

A “manual” setting on the front panel bypasses the AT-MX341a’s automatic switching and attenuation functions, causing the unit to behave like a conventional 4-channel mixer. In this mode, the relative level of each microphone is strictly a function of the position of its respective front-panel gain control.

AT-MX341a Front Panel

1. **Power switch.**
2. **Power “on” indicator.**
3. **Input Gain controls.** Adjust inputs for microphone sensitivities and/or operating conditions.
4. **Selected Channel LED indicators.** Indicate which channels are “on” or “active.”
5. **Output Level LED meter.** Indicates RMS output level of the mixer. “Zero” (0) level is factory calibrated for an output of +4 dBm into 600 ohms (Master Level control fully clockwise). Can be set for peak output level indication via internal switch (see page 8).
6. **Priority Pre-select switches.** A switch in the “up” position assigns the respective channel priority over the other channels. A priority channel can not be locked out by other channels. Any combination of priority/non-priority selections is allowed.
7. **Master Level control.** Normal setting is fully clockwise (full output). If reducing the mixer’s output is necessary, carefully turn the control counter-clockwise as needed with a small screwdriver. Once set as desired, the control may be protected from unauthorized adjustment by covering the panel hole with a sticker provided with the security caps. (This control does **not** affect the meter indication.)
8. **Master Threshold/Manual control.** Sets the reference level that must be exceeded for a microphone to be considered “in use.” Adjust to keep background noise level from triggering microphones. “Manual” setting bypasses all of the SmartMixer’s automatic functions.
9. **Lockout LED indicator.** Shows when lockout bus is active. Also aids in setting Master Threshold.

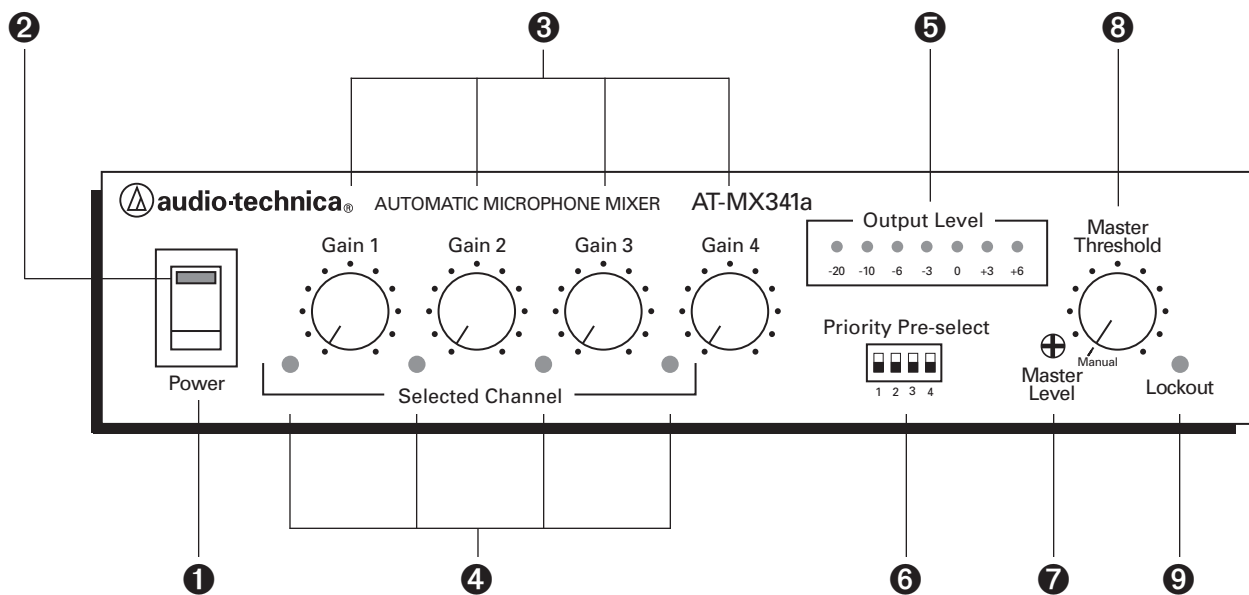

Figure 1. Front panel

AT-MX341a Rear Panel

1. **Power input.** Requires 12 volts AC or 15 volts DC, either polarity; 150 mA minimum.
2. **Link In/Out.** Provides for daisy-chaining of multiple mixers when more than four microphones are used.
3. **Control Voltage Out.** Provides 0 to +4 VDC (active high) to trigger external devices such as speaker switching, camera switching and indicator lights.
4. **Output.** Balanced line-level output. Can be changed to mic-level output via internal switch (see page 7). XLRM-type connector.
5. **Inputs.** Balanced microphone inputs for low impedance dynamic or condenser mics. Can be changed to line-level inputs via internal switches (see page 7). XLRF-type connectors.

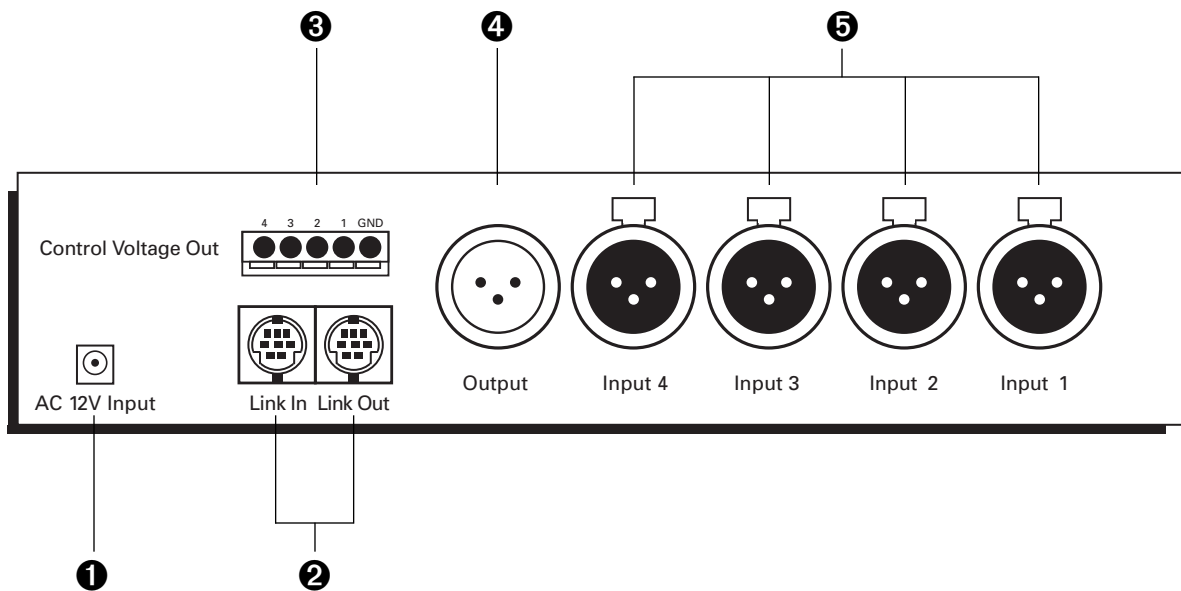

Figure 2. Rear panel

Installation and Setup

AT-MX341a SmartMixer setup tips:

1. Turn Master Threshold control to minimum threshold, immediately clockwise of the “Manual” setting.
2. Set all Priority DIP switches to “down” position.
3. Turn all four microphone Gain controls fully counter-clockwise.
4. Connect the AC adapter to the mixer and plug in to outlet.
5. Turn Power switch “on.” The mixer will perform a self-test and turn each microphone “on” and “off” consecutively.
6. Connect a microphone to Input 1 and turn the Gain 1 control to the “nine o’clock” position. The channel 1 LED will light if the microphone is operational.
7. Adjust the Gain 1 control for proper meter indication when speaking into microphone (peaks at 0).
8. Gradually increase the Master Threshold control until the Lockout LED flashes when speaking at a normal level.
9. Plug in up to three other microphones and adjust each respective Gain control for proper meter indication. It should not be necessary to readjust the threshold level.
10. Priority can be assigned to one or more microphones by moving the appropriate DIP switch(es) to the “up” position. Any microphone(s) assigned in this manner cannot be locked out by any other microphone.
11. “Manual” mode can be selected at any time by simply turning the Master Threshold control fully counterclockwise. In this mode, the unit will behave like a conventional four-channel microphone mixer (all automatic functions are bypassed).
12. The Master Level recessed control on the front panel may be adjusted with a small screwdriver if necessary. This control is at the last stage in the mixer, and does not affect microphone gain, threshold setting, or meter indication.

Priority Microphones and the Lockout Bus

Once the Master Threshold control has been properly adjusted, an audio signal appearing in *any* channel causes the lockout control bus to activate and the Lockout LED indicator to light. The Priority Pre-select switches then determine whether or not a particular mic is affected by lockouts caused by other mics: a channel Priority switch in the “down” position *will allow* lockout* of its mic; the same switch “up” *will not allow* lockout of its mic.

** Note that any mic which is described as “locked out” or “off” is really just being attenuated by between 6 dB and 20 dB from the level otherwise determined by its Gain control setting, sensitivity and placement. See the “Daisy-chaining Mixers” section on page 10 for further details.*

There are basically three “modes” of automatic operation:

Mode 1... All Priority Pre-select switches *Up*

The Lockout indicator will come on with any audio input, but no mic will be locked out...because none are connected to the lockout bus. (This mode is often called “Free-for-all”...or sometimes “City Council”!)

Mode 2...All Priority Pre-select switches Down

In this mode, only one mic at a time can be “on.” The lockout bus shuts down all other mics until the first speaker pauses. As soon as the controlling microphone goes silent, the lockout bus goes inactive and any other mic can come on. This switching takes place without any syllable-grabbing delay, or pops or clicks. (This mode is known as “First-come-first-served” or “Filibuster.”)

This mode is very useful when the gain setting of the overall sound system must be close to the threshold of feedback, and additional microphones coming on could throw the system into feedback. The SmartMixer will not allow multiple microphones to be on at the same time in this mode. The switching is so fast and silent that the meeting can still be completely interactive.

Mode 3...One Priority Pre-select switch Up

The selected priority microphone can come on at any time and can override any other mic that is on (popularly called “The Chairperson” mode).

(Note that there may be special circumstances where two or three mics could be set to priority, so those speakers could talk whenever desired, but still override one or two non-priority mics.)

If multiple SmartMixers are used with AT8325/1.0 Link Cables, Priority Pre-select switches on all channels in use will have the control effects described above.

Preamplifier Gain

The SmartMixer has a substantial gain range, allowing it to accept a wide variety of microphones. However, if in some instances higher-output microphones are used for close talking, it may be necessary to reduce the preamplifier gain. This can be done by changing switch settings inside the unit. With the unit unplugged, remove the two screws on each side of the unit and remove the top cover. Locate the internal switches designated on the circuit board by “SW9,” “SW10,” “SW11” and “SW12” (Figs. 3 and 4, page 8). Changing the settings of these internal switches will cause a gain reduction of 10 dB for channels 1, 2, 3 and 4 respectively.

The preamplifier gain may be reduced further, allowing the SmartMixer to accept line-level sources. Changing the settings of the internal switches designated by “SW1,” “SW2,” “SW3” and “SW4” will cause an input reduction of 50 dB for channels 1, 2, 3 and 4 respectively. Note that the appropriate internal switches can be used in combination for a total sensitivity reduction of up to 60 dB for each channel.

Output Gain

The SmartMixer’s output is factory set at line level. Should mic-level output be desired, simply unplug the unit, remove the top cover and locate the switch on the circuit board marked “SW15” (Figs. 3 and 4, page 8). Changing the setting of this switch will cause a 50 dB reduction in output.

Phantom Power

Each of the SmartMixer’s inputs supplies +12V DC phantom power. Should it be required to disable the phantom power, simply unplug the unit, remove the top cover and locate the switches designated on the circuit board by “SW5,” “SW6,” “SW7” and “SW8” (Figs. 3 and 4, page 8). Changing the settings of these switches will disable phantom power on channels 1, 2, 3 and 4, respectively. Note that, although they do not require phantom power for operation, most balanced-output dynamic microphones can be used without disabling the SmartMixer’s phantom power.

Output Level LED Meter

The Output Level LED meter is factory set to indicate RMS output. Should peak output indication be desired, simply unplug the unit, remove the top cover and change the setting of the switch designated on the circuit board by “SW16” (Figs. 3 and 4). “Zero” (0) level is factory-calibrated at +4 dBm into 600 ohms.

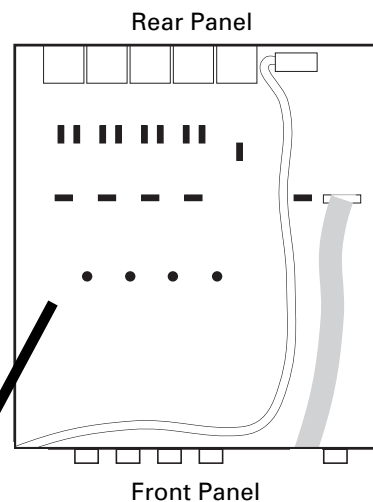

Figure 3. Internal view of mixer.

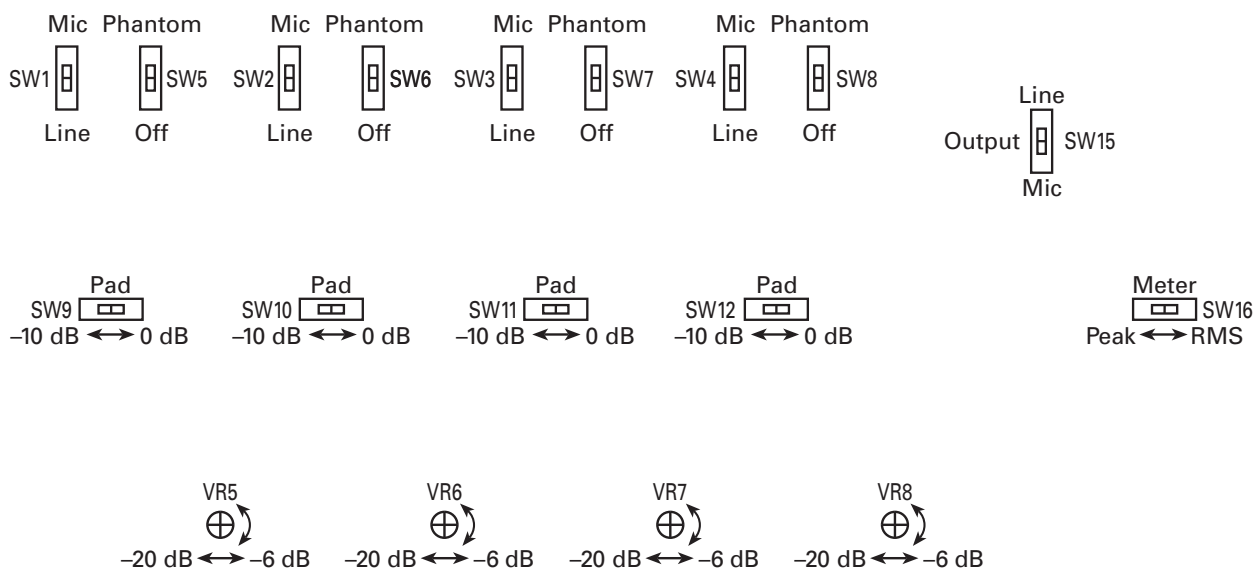

Figure 4. Detail of internal controls.

Adjusting “Off” Attenuation

In instances when the number of microphones in use is high, it may be necessary to increase the amount of “off” attenuation per microphone to keep the total ambient noise level low. There are “off” attenuation adjustments inside the unit. To adjust the “off” attenuation of channel 1, unplug the unit, remove the top cover and locate the trimpot designated on the circuit board by “VR5” (Figs. 3 and 4). It is factory set at approximately 8 dB, the attenuation at the middle of the control’s rotation. When the control is turned fully counter-clockwise, “off” attenuation is approximately 20 dB. Conversely, when the adjustment is turned fully clockwise, “off” attenuation is approximately 6 dB. VR6, VR7 and VR8 control “off” attenuation for channels 2, 3 and 4 respectively.

Control Voltage Out

When a microphone channel turns “on,” as indicated by a Selected Channel LED on the front panel, the channel’s associated Control Voltage Out goes “high” (+4 VDC). This signal can be used to light indicator lamps, switch speaker zones on and off, select video cameras, etc. *The control voltage should not be connected directly to an inductive load such as a relay coil, as damage to the mixer may result.* Several interface circuit possibilities are shown in Figure 5.

Equivalent Output Circuit for Control Voltage Out

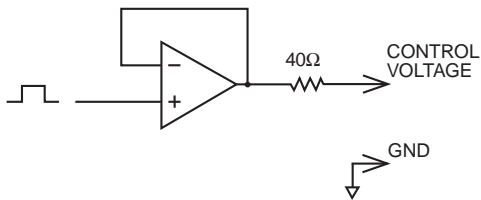

Driving One LED

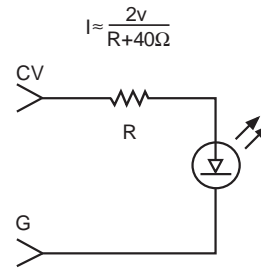

Relay Driver

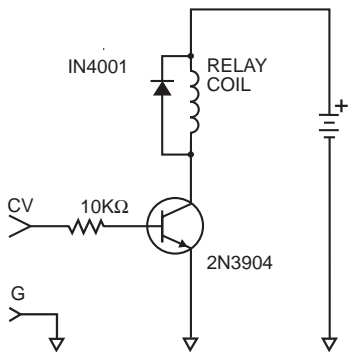

Driving Lamps

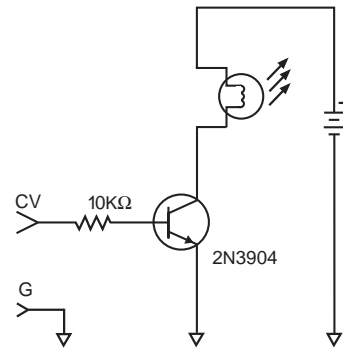

Driving Logic Gates

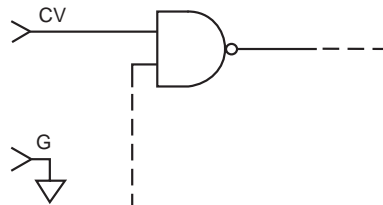

Figure 5. Control interface examples.

Daisy-chaining Mixers

When more than four microphones are needed, it is possible to daisy-chain multiple SmartMixers together through the Link In/Out connectors on the backs of the units (Fig. 2). Connect Mixer #1 Link Out jack to Mixer #2 Link In jack, etc. Mixer #1 output contains only audio from the first four microphones; Mixer #2 output then contains audio from all the microphones plugged into Mixer #1 *and* the microphones plugged into Mixer #2. The last mixer in the chain contains audio from all preceding mixers. The combined output is then taken from the *last* mixer in the chain. Because lockout information is passed between mixers through Link In/Out, the last-microphone-on condition is not violated. Thus only one microphone per installation will stay on when no one is speaking.

Note that one or more mixers can be switched to “Manual” mode without affecting the automatic operation of any other mixers in the chain.

Rack Mounting

Provided with each mixer are two rack ears, one long and one short, and six self-tapping screws to attach the ears to the unit. When using more than one SmartMixer in a system, it may be advantageous to mount two mixers in a 1U rack space. This can be accomplished using the two short rack ears and an optional joining plate (Model AT8628), which allows two units to be connected side-by-side in a single rack space.

Security Caps

For permanent installations where microphone selections, positions and acoustic conditions are constant, it may be advantageous to remove the front panel knobs and install security caps to prevent unauthorized adjustments. To install, simply press the caps into place, covering the Gain and Threshold controls. Place the provided sticker over the Master Level access opening in the panel. The system should be tested carefully before installing the security caps because they are intended to be “permanent” and are very difficult to remove.

If removal of installed security caps becomes necessary, first remove the two screws on each side of the unit and remove the top cover. Then remove the six screws that attach the front panel: four on top and two underneath. Remove the front panel. With the panel removed, the two locking tabs on each security cap can be accessed. The cap can be released by carefully squeezing the two tabs together.

Specifications[†]

Input Impedance	
Mic	4,000 ohms
Line	30,000 ohms
Output Impedance	
Line	200 ohms
Mic	320 ohms
Maximum Input Level	
Mic	-20 dBV
Line	30 dBV
Maximum Output Level*	
Line	+14 dBm (600 ohms)
Mic	-40 dBm (600 ohms)
Nominal Output Level (0 VU)*	
Line	+4 dBm (600 ohms), +4.4 dBV (open circuit)
Mic	-46 dBm (600 ohms), -44 dBV (open circuit)
Maximum Gain	≥70 dB
Frequency Response	60 Hz to 30 kHz at -3 dB points
Dynamic Range ¹	75 dB ±10 dB, dependent upon gain control settings
Equivalent Input Noise	-120 dBV (150 ohms) at maximum gain
Input Attenuation	10 dB
Mic/Line Input Pads	50 dB
Microphone Phantom Power	+12V DC
Control Voltage Out	+4V DC
Power Supply	12V AC, 150 mA, min.
Operating Temperature	32° to 104° (0° to 40° C)
Dimensions	8.25" (210 mm) W x 9.38" (327 mm) D x 1.75" (44 mm) H (including feet, knobs and connectors)
Weight	3 lbs. 7 oz (1.6 kg)
Included Accessories	AC power supply, AT8325/1.0 Link Cable
Optional Accessory	AT8628 Double Rackmount Joining Plate

[†] In the interest of standards development, A.T.U.S. offers full details on its test methods to other industry professionals on request.

* Master Level control at maximum (fully clockwise).

¹ Input terminated with 150 ohms, A-weighted using Audio Precision System One.

Summary of Internal Controls					
Function	Ch 1	Ch 2	Ch 3	Ch 4	Output
50 dB Mic/Line Atten.	SW1	SW2	SW3	SW4	SW15
12V Phantom Power	SW5	SW6	SW7	SW8	--
10 dB Input Atten.	SW9	SW10	SW11	SW12	--
"Off" Attenuation	VR5	VR6	VR7	VR8	--
Meter RMS/Peak	--	--	--	--	SW16

See diagram on page 8 for locations/positions.

One-Year Limited Warranty

Audio-Technica brand products purchased in the U.S.A. are warranted for one year from date of purchase by Audio-Technica U.S., Inc. (A.T.U.S.) to be free of defects in materials and workmanship. In event of such defect, product will be repaired promptly without charge or, at our option, replaced with a new product of equal or superior value if delivered to A.T.U.S. or an authorized service center prepaid, together with the sales slip or other proof of purchase date. **Prior approval from A.T.U.S. is required for return.** This warranty excludes defects due to normal wear, abuse, shipping damage, or failure to use product in accordance with instructions. This warranty is void in the event of unauthorized repair or modification.

For return approval and shipping information, contact the Service Department, Audio-Technica U.S., Inc., 1221 Commerce Drive, Stow, Ohio 44224.

Except to the extent precluded by applicable state law, **A.T.U.S. will have no liability for any consequential, incidental, or special damages; any warranty of merchantability or fitness for particular purpose expires when this warranty expires.**

This warranty gives you specific legal rights, and you may have other rights which vary from state to state.

Outside the U.S.A., please contact your local dealer for warranty details.



audio-technica®

Audio-Technica U.S., Inc., 1221 Commerce Drive, Stow, Ohio 44224 330/686-2600