

Relay / Input / Output Transformer-Balanced Module

Model RIO1S



Description

Bogen's RIO1S is a multi-functional module with a priority controlled relay contact, transformer-balanced input, transformer-balanced output, and an RJ11 output for direct connection to the override input of a zone paging system.

The RIO1S provides a convenient way to integrate a Power Vector amplifier with a PCM zone paging system, allowing full use of the Power Vector's priority structure in zone paging applications for more sophisticated paging capabilities.

Features

- Transformer-isolated, balanced line-level input
- 600- or 10k-ohm (jumper selectable) input impedance
- Transformer-isolated, balanced line-level output
- 8-ohm, 0.75W output
- Input and output level controls
- Relay responds to jumper selectable priority level
- N.O. or N.C. jumper selectable relay contact
- External control of priority muting buses
- Input can be muted from higher priority modules, with signal fade back
- Output (normally gate) can be synced with priority relay operation
- Output gating can be defeated via jumper
- RJ11 connection with line output and dedicated N.O. relay contact (allows easy connection to O/R port of Bogen telephone paging interfaces)

Block Diagram

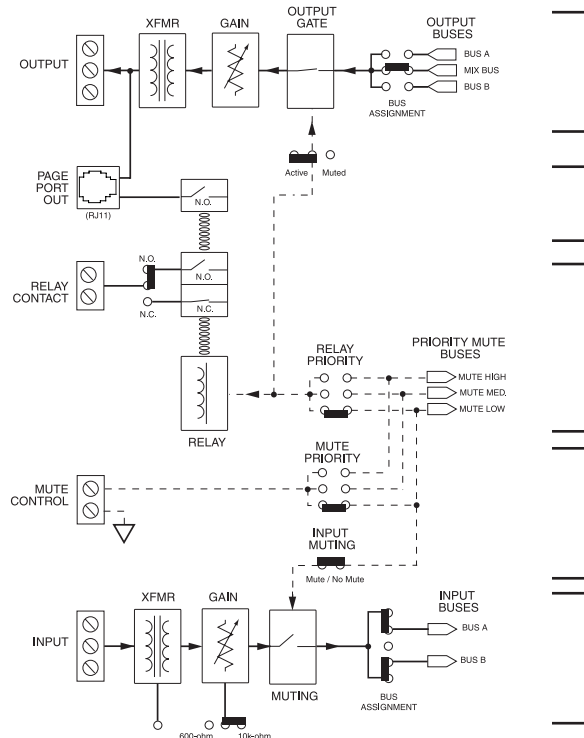

Output

- Jumper selectable transformer-balanced output with gain and priority gating (sync'd with prioritized relay)

Page Port Output

- Specialized PCM2000 / Page Port type output with audio signal and dedicated N.O. contact (RJ11 jack)

Relay Contact

- Prioritized Relay (N.O. or N.C. contact) allows external devices to be activated when specific priority levels are met

Mute Control

- External control of priority mute buses

Input

- Transformer-balanced (600-ohm or 10k-ohm) input with gain and defeatable priority mute



Specifications subject to change without notice.
© 2004 Bogen Communications, Inc.
Part No. 54-8019-01A Printed in U.S.A. 0406

Technical Specifications

Feature	Input	Output
Gain	-11 dB to +19 dB	OFF to 0 dB/+7 dB (8-ohm/600-ohm load)
Frequency Response	10 Hz to 40 kHz (+0/-3 dB)	30 Hz to 20 kHz (+0/0.5 dB) with 8-ohm load, 0.75W
Distortion	<0.3% 20 Hz to 20 kHz @ 1V	<1% w/8-ohm load, 0.75W (30 Hz - 20 kHz)
Impedance	600 ohms/10k ohms (jumper selectable), Balanced	8 ohms minimum, Balanced
Priority	Mute Low (jumper defeatable)	Three Levels (normally gated)
S/N (20 Hz - 20 kHz)	-75 dBV	
Muting	>50 dB	
Controls	Level IN, Level OUT	
Connector(s)	Screw terminals and RJ11	
Power	± 24V DC	
Product Weight	4.1 oz.	
Dimensions	1 ³ / ₈ " W x 3 ¹ / ₈ " H x 3 ¹ / ₂ " D	

Architect & Engineer Specifications

The module shall be a Bogen Model RIO1S relay/input/output transformer balanced module.

Input

The RIO1S shall have a transformer-isolated, balanced line-level input. The input connection shall be made via a screw terminal connector.

It shall have a jumper selectable input impedance of 600 ohms or 10k ohms. It shall include a level control with a gain range from -11 dB to +19 dB.

The input shall be mutable by higher priority modules with signal fade back. Muting shall be jumper defeatable.

The module's input signal can be jumper-configured to Bus A, Bus B, or both.

Output

The RIO1S shall have a transformer-isolated, balanced line-level output. The output can be selected to turn on when a user-selected priority level is met or to be on continuously.

The output connection shall be made via a screw terminal connector. It shall include a level control with a gain control range from OFF to 0 dB/+7 dB (8-ohm / 600-ohm load).

The output shall be capable of being loaded down to 8 ohms/0.75W.

The module's output signal can be jumper-configured from either Bus A, Bus B, or Mix Bus.

Page Port Output

The page port output connection shall be made via an RJ11 connector. It shall contain a dedicated N.O. contact and output signal.

Relay Contact

The RIO1S shall provide a relay contact that will respond to any of three priority levels (jumper selectable). The relay connection shall be made via a screw terminal connector.

The relay contact (N.O. or N.C.) shall have a rating of 0.6A @ 120V AC or 2A @ 30V DC.

Mute Control

The RIO1S shall provide external access to each of the priority buses (jumper selectable) through the mute control. The mute control connection shall be made via a screw terminal connector.

The RIO1S shall measure 1³/₈" W x 3¹/₈" H x 3¹/₂" D and shall weigh 4.1 ounces.

BOGEN[®] COMMUNICATIONS, INC.

50 Spring Street, Ramsey, New Jersey 07446, U.S.A.
 201-934-8500 FAX: 201-934-9832
 Web Site: www.bogen.com